



USER MANUAL UMAX141810
USER MANUAL UMAX141830

RS485-MODBUS-ENET MODBUS ROUTER WITH ETHERNET AND CAN

USER MANUAL

P/N: AX141810, AX141830

VERSION HISTORY

Version	Date	Author	Modification
1.0.0.	May 24, 2021	Antti Keränen	Initial Draft
-	May 25, 2021	A. Wilkins	Added dimensional drawing, weight, vibration and shock, updated technical spec to 05/2021 version, added Ethernet to pinout
1.0.1	September 14, 2023	Kiril Mojsov	Performed Legacy Updates



The default passwords:
AX141810 firmware: '**AX141810**'
AX141830 firmware: '**AX141830**'

ACCRONYMS

ACK	Positive Acknowledgement (from SAE J1939 standard)
BATT +/-	Battery positive (a.k.a. Vps) or Battery Negative (a.k.a. GND)
DM	Diagnostic Message (from SAE J1939 standard)
DTC	Diagnostic Trouble Code (from SAE J1939 standard)
EA	The Axiomatic Electronic Assistant (A Service Tool for Axiomatic ECUs)
ECU	Electronic Control Unit (from SAE J1939 standard)
GND	Ground reference (a.k.a. BATT-)
I/O	Inputs and Outputs
IP	Internet Protocol
MAC	Media Access Control
MAP	Memory Access Protocol
MB	Modbus
NAK	Negative Acknowledgement (from SAE J1939 standard)
PDU1	A format for messages that are to be sent to a destination address, either specific or global (from SAE J1939 standard)
PDU2	A format used to send information that has been labeled using the Group Extension technique, and does not contain a destination address.
PGN	Parameter Group Number (from SAE J1939 standard)
PropA	Message that uses the Proprietary A PGN for peer-to-peer communication
PropB	Message that uses a Proprietary B PGN for broadcast communication
SPN	Suspect Parameter Number (from SAE J1939 standard)
TCP/IP	Transmission Control Protocol / Internet Protocol
TP	Transport Protocol
Vps	Voltage Power Supply (a.k.a. BATT+)

Note:

An Axiomatic Electronic Assistant KIT may be ordered as P/N: AX070502, or AX070506K

TABLE OF CONTENTS

1. OVERVIEW OF CONTROLLER	7
2. INSTALLATION INSTRUCTIONS	8
2.1. Dimensions and Pinout.....	8
3. OVERVIEW OF J1939 FEATURES.....	9
3.1. Introduction to Supported Messages.....	9
3.2. NAME, Address and Identification Information.....	10
4. WEB BROWSER BASED CONTROLLER CONFIGURATION	13
5. ECU SETPOINTS ACCESSED WITH THE AXIOMATIC ELECTRONIC ASSISTANT.....	22
5.1. J1939 Network Setpoints.....	22
5.2. Ethernet Parameter Setpoints	23
5.3. RS485 Parameter Setpoints.....	24
6. REFLASHING OVER CAN WITH THE AXIOMATIC EA BOOTLOADER.....	25
APPENDIX A - TECHNICAL SPECIFICATION.....	A-1

List of Figures

Figure 1 – Block diagram of the RS485-MODBUS Converter with Ethernet and CAN.....	7
Figure 2 – Controller Dimensions and Label	8
Figure 3 – Screen Capture of J1939 Setpoints	22
Figure 4 – Screen Capture of Ethernet Parameter Setpoints	23
Figure 5 – Screen Capture of RS485 Parameter Setpoints	24

List of Tables

Table 1 – AX141810/AX141830 Connector Pinout.....	8
Table 2 – J1939 Setpoints.....	22
Table 3 – Ethernet Parameter Setpoints	23
Table 4 – RS485 Parameter Setpoints.....	24

REFERENCES

J1939	Recommended Practice for a Serial Control and Communications Vehicle Network, SAE, April 2011
J1939/21	Data Link Layer, SAE, December 2010
J1939/71	Vehicle Application Layer, SAE, March 2011
J1939/73	Application Layer-Diagnostics, SAE, February 2010
J1939/81	Network Management, SAE, May 2003
TDAX141810	Technical Datasheet, RS485-MODBUS-ENET Converter, Axiomatic Technologies 2021
UMAX07050x	User Manual, Axiomatic Electronic Assistant and USB-CAN, Axiomatic Technologies, 2023

This document assumes the reader is familiar with the SAE J1939 standard. Terminology from the standard is used, but not described in this document.



NOTE: This product is supported by Axiomatic Electronic Assistant V<TBD> and higher

1. OVERVIEW OF CONTROLLER

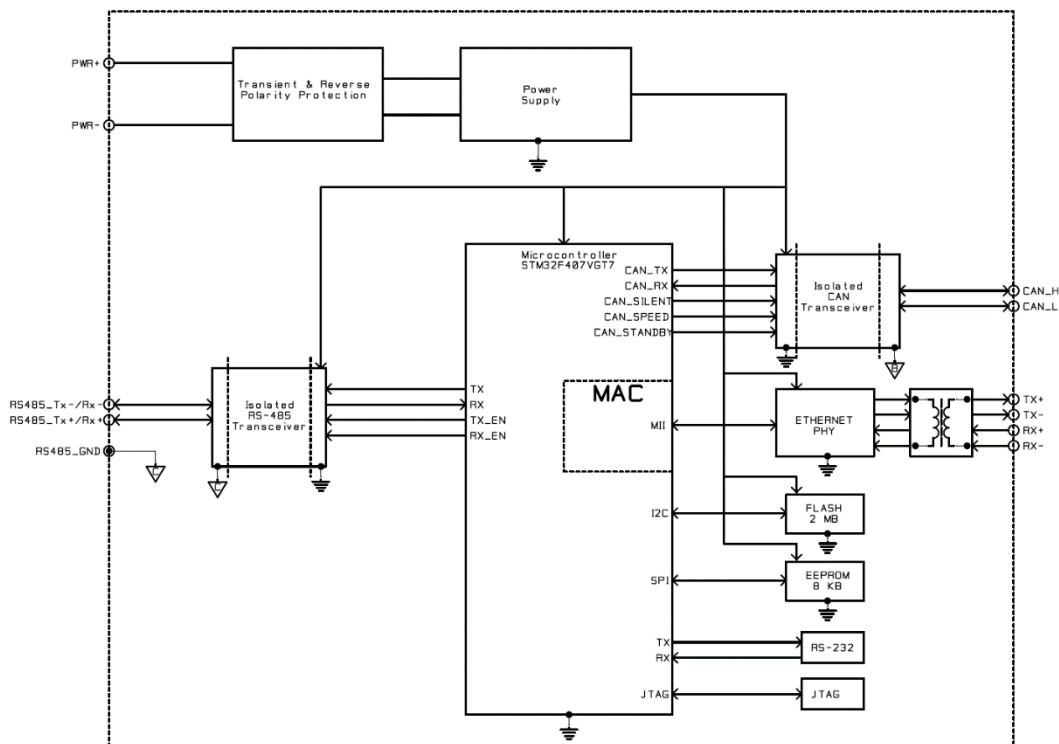

Figure 1 – Block diagram of the RS485-MODBUS Converter with Ethernet and CAN

The RS485-MODBUS Converter with Ethernet and CAN (later RS485-MODBUS-ENET) is a device that forwards Modbus data between the serial port (RTU), CAN and Ethernet based on a custom routing configuration. The configuration can be done using a web browser and the built-in web server running on the RS485-MODBUS-ENET device.

The Axiomatic Electronic Assistant is used to configure the network parameters (both RS485 and Ethernet) of the RS485-MODBUS-ENET device. The configuration of the rest of the parameters can be done via the web browser interface (port 80).

The two firmware versions, AX141810 and AX141830 both support the same data routing functions. The difference is in the amount of routing rules and message definitions. The AX141810 is a general-purpose device with support for both directions, Modbus (RTU+TCP/IP) to CAN and vice versa.

The AX141830 is targeted mainly for CAN to Modbus (RTU+TCP/IP) direction.

2. INSTALLATION INSTRUCTIONS

2.1. Dimensions and Pinout

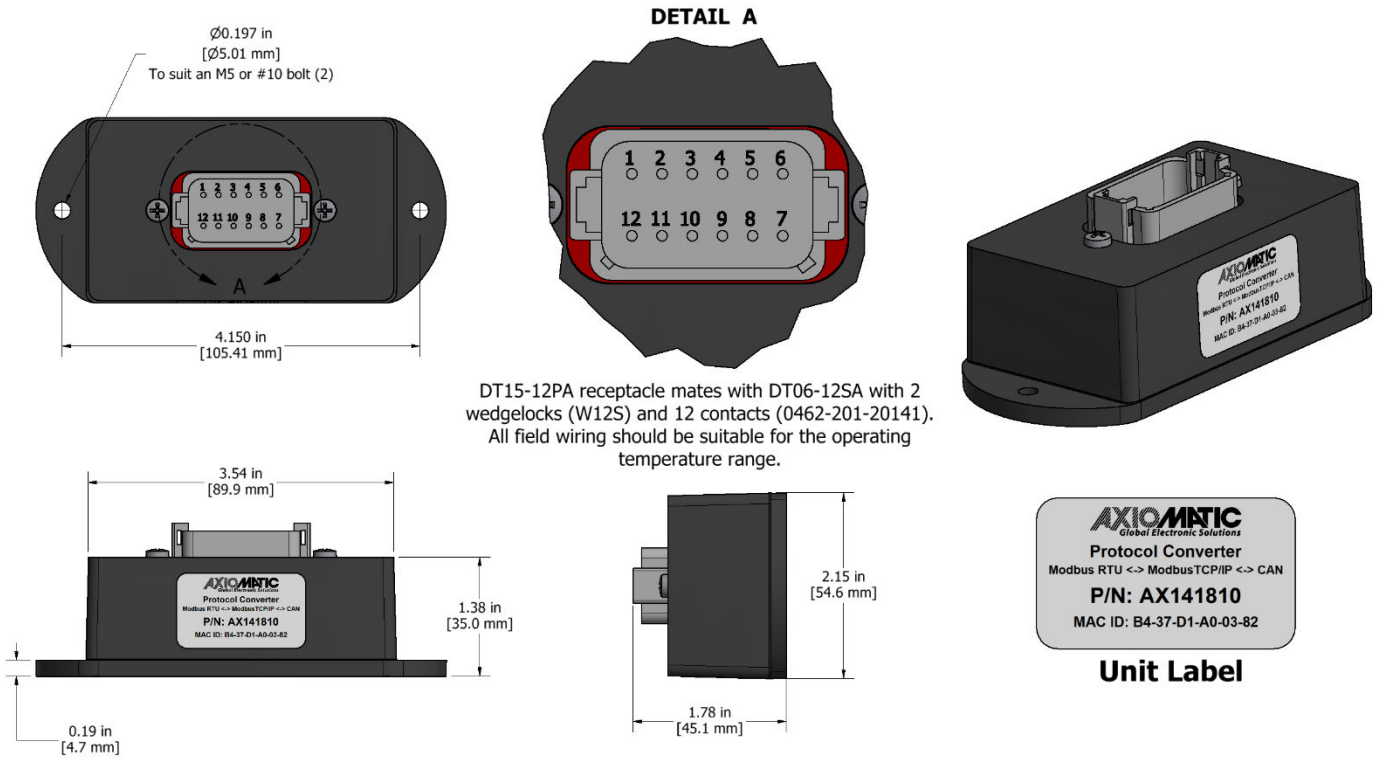

Figure 2 – Controller Dimensions and Label

CAN and I/O Connector	
Pin #	Description
1	BATT-
2	Ethernet TX+
3	Ethernet RX+
4	RS485 TX+/RX+
5	CAN_SH
6	CAN_H
7	CAN_L
8	RS485_GND
9	RS485 TX-/RX-
10	Ethernet RX-
11	Ethernet TX-
12	BATT+

Table 1 – AX141810/AX141830 Connector Pinout

3. OVERVIEW OF J1939 FEATURES

The software was designed to provide flexibility to the user with respect to messages sent from the ECU by providing:

- Configurable ECU Instance in the NAME (to allow multiple ECUs on the same network)
- Configurable PGN and Data Parameters
- Configurable Diagnostic Messaging Parameters, as required

3.1. Introduction to Supported Messages

The ECU is compliant with the standard SAE J1939, and supports following PGNs from the standard.

From J1939-21 – Data Link Layer

- Request 59904 0x00EA00
- Acknowledgement 59392 0x00E800
- Transport Protocol – Connection Management 60416 0x00EC00
- Transport Protocol – Data Transfer Message 60160 0x00EB00
- Proprietary B from 65280 0x00FF00
to 65535 0x00FFFF

From J1939-73 – Diagnostics

- DM1 – Active Diagnostic Trouble Codes 65226 0x00FECA
- DM2 – Previously Active Diagnostic Trouble Codes 65227 0x00FECB
- DM3 – Diagnostic Data Clear/Reset for Previously Active DTCs 65228 0x00FECC
- DM11 – Diagnostic Data Clear/Reset for Active DTCs 65235 0x00FED3

From J1939-81 – Network Management

- Address Claimed/Cannot Claim 60928 0x00EE00
- Commanded Address 65240 0x00FED8

From J1939-71 – Vehicle Application Layer

- ECU Identification Information 64965 0x00FDC5
- Software Identification 65242 0x00FEDA
- Component Identification 65259 0x00FEEB

None of the application layer PGNs are supported as part of the default configurations, but they can be selected as desired for transmit function blocks.

Setpoints are accessed using standard Memory Access Protocol (MAP) with proprietary addresses. The Axiomatic Electronic Assistant (EA) allows for quick and easy configuration of some of the unit's main parameters over CAN network.

3.2. NAME, Address and Identification Information

The RS485-MODBUS-ENET has the following default for the J1939 NAME. The user should refer to the SAE J1939/81 standard for more information on these parameters and their ranges.

Arbitrary Address Capable	Yes
Industry Group	0, Global
Vehicle System Instance	0
Vehicle System	0, Non-specific system
Function	25, Axiomatic Protocol Converter
Function Instance	23/24, Axiomatic AX141810/AX141830
ECU Instance	0, First Instance
Manufacture Code	162, Axiomatic Technologies
Identity Number	Variable, uniquely assigned during factory programming for each ECU

The ECU Instance is a configurable setpoint associated with the NAME. Changing this value will allow multiple ECUs of this type to be distinguishable from one another when they are connected on the same network.

The default value of the “ECU Address” setpoint is 128 (0x80), which is the preferred starting address for self-configurable ECUs as set by the SAE in J1939 tables B3 and B7. The Axiomatic EA supports the selection of any address between 0 and 253. ***It is user’s responsibility to select an address that complies with the standard.*** The user must also be aware that since the unit is arbitrary address capable, if another ECU with a higher priority NAME contends for the selected address, the RS485-MODBUS-ENET will continue select the next highest address until it finds one that it can claim. See J1939/81 for more details about address claiming.

ECU Identification Information

PGN 64965		ECU Identification Information		-ECUID
Transmission Repetition Rate:		On request		
Data Length:		Variable		
Extended Data Page:		0		
Data Page:		0		
PDU Format:		253		
PDU Specific:		197 PGN Supporting Information:		
Default Priority:		6		
Parameter Group Number:		64965 (0x00FDC5)		
Start Position	Length	Parameter Name	SPN	
a	Variable	ECU Part Number, Delimiter (ASCII "**")	2901	
b	Variable	ECU Serial Number, Delimiter (ASCII "**")	2902	
c	Variable	ECU Location, Delimiter (ASCII "**")	2903	
d	Variable	ECU Type, Delimiter (ASCII "**")	2904	
e	Variable	ECU Manufacturer Name, Delimiter (ASCII "**")	4304	
(a)*(b)*(c)*(d)*(e)*				

Software Identifier

PGN 65242		Software Identification		-SOFT
Transmission Repetition Rate:		On request		
Data Length:		Variable		
Extended Data Page:		0		
Data Page:		0		
PDU Format:		254		
PDU Specific:		218 PGN Supporting Information:		
Default Priority:		6		
Parameter Group Number:		65242 (0x00FEDA)		
Start Position	Length	Parameter Name	SPN	
1	1 Byte	Number of software identification fields	965	
2-n	Variable	Software identification(s), Delimiter (ASCII "**")	234	

Byte 1 is set to 5, and the identification fields are as follows.

(Part Number)*(Version)*(Date)*(Owner)*(Description)

The Axiomatic EA shows all this information in its "General ECU Information" page. *Note: The information provided in the Software ID is available for any J1939 service tool which supports the PGN -SOFT*

Component Identification

PGN 65259		Component Identification	-CI
Transmission Repetition Rate:		On request	
Data Length:		Variable	
Extended Data Page:		0	
Data Page:		0	
PDU Format:		254	
PDU Specific:		235 PGN Supporting Information:	
Default Priority:		6	
Parameter Group Number:		65259 (0x00FEEB)	
Start Position	Length	Parameter Name	SPN
a	1-5 Byte	Make, Delimiter (ASCII “*”)	586
b	Variable	Model, Delimiter (ASCII “*”)	587
c	Variable	Serial Number, Delimiter (ASCII “*”)	588
d	Variable	Unit Number (Power Unit), Delimiter (ASCII “*”)	233
(a)*(b)*(c)*(d)*(e)*			

4. WEB BROWSER BASED CONTROLLER CONFIGURATION

The RS485-MODBUS-ENET controller supports configuration of the data routing parameters from Ethernet port using a standard web browser.

The web browser based configuration requires a password before any of the parameters can be viewed or edited.



The default passwords:

AX141810 firmware: '**AX141810**'

AX141830 firmware: '**AX141830**'

4.1. Parameter Editing

The RS485-MODBUS-ENET has a web server running on TCP port 80. Please note that the “Save settings” button has to be clicked for saving the parameters. If not clicked, the modified parameters are discarded when moving to another configuration page or closing the web browser. The RS485-MODBUS-ENET web server supports the configuration options described on the following pages.

<configured ip>

<configured ip>/index.shtml

The screenshot displays the web interface for the AX141810 ModbusRTU - ModbusTCP/IP Converter. The browser address bar shows the URL `192.168.1.20/index.shtml`. The page features a navigation menu on the left with links to Home, Main Settings, CAN RX Settings, CAN TX Settings, Modbus Slave Settings, Modbus Master Settings, Diagnostics Routing Settings, and Upload/Download. The main content area is divided into several sections:

- DEVICE INFORMATION:** Part Number: AX141830, Serial Number: 0019220007, Firmware Version: V1.00
- ETHERNET:** MAC Address: B4:37:D1:A2:56:98. Includes Server (Device IP Address: 192.168.1.20, Web Server Port: 80, Device Subnet Mask: 255.255.255.0) and Client (Remote IP Address: 192.168.1.1, Remote Port: 502) settings.
- CAN:** Baud Rate: 500 kbit/s, Auto Baud Rate Enabled: Yes
- RS485:** RS485 settings: 9600, 8N1
- DIAGNOSTICS:** CAN Frames Received: 0, CAN Frames Sent: 23, RS485 Frames Received: 0, RS485 Frames Sent: 0, Ethernet Messages Received: 303, Ethernet Messages Sent: 272

The Home page (index.shtml) shows the main configuration parameters and some communication statistics (number of messages for each interface).

<configured ip>/main_settings.shtml

The Main Settings configuration page allows the user to modify the device's IP address, netmask and the main configuration parameters for the communication interfaces. The CAN configuration parameters include the default baud rate to use and the auto-baud rate capability.

The serial port configuration contains baud rate (freely settable in range 75...256000), number of data, start and stop bits and parity.

The password can be changed by entering the same password to both 'New password' and 'Retype new password' entries. In case the 'Retype new password' is left empty or the two passwords don't match, the password is not modified.

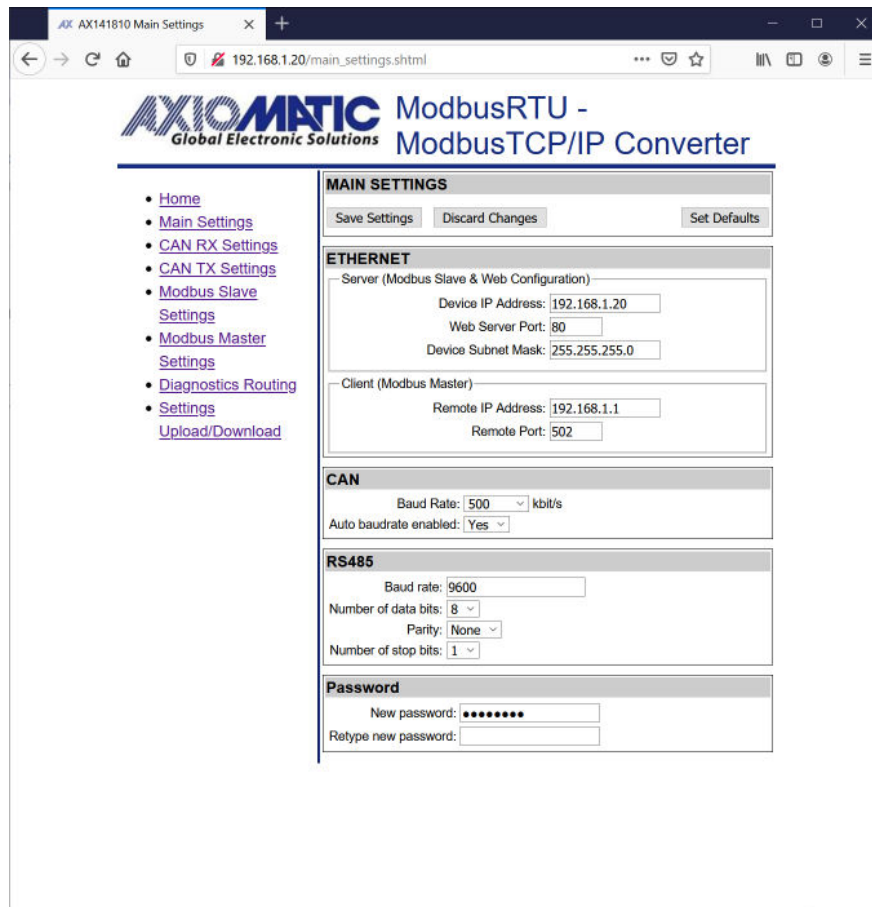

AXIOMATIC Global Electronic Solutions ModbusRTU - ModbusTCP/IP Converter

MAIN SETTINGS

Save Settings Discard Changes Set Defaults

ETHERNET

Server (Modbus Slave & Web Configuration)

Device IP Address: 192.168.1.20
Web Server Port: 80
Device Subnet Mask: 255.255.255.0

Client (Modbus Master)

Remote IP Address: 192.168.1.1
Remote Port: 502

CAN

Baud Rate: 500 kbit/s
Auto baudrate enabled: Yes

RS485

Baud rate: 9600
Number of data bits: 8
Parity: None
Number of stop bits: 1

Password

New password:
Retype new password:

<configured ip>/can_rx_settings.shtml

The CAN receive message parameter settings are displayed one message at a time. The message can be selected using the 'Next' and 'Previous' buttons. The 'Jump to' button selects the specified message directly. Please remember to save settings before selecting another CAN receive message to be configured, otherwise the modified settings will be lost.

The 'Discrete' data type reads in the CAN data as a number (or bit field data), using the range specified by the configured number of bits (Data width). With discrete data types, the resolution, offset, minimum and maximum are not used.

The 'Continuous' data type uses the J1939 data formatting with resolution, offset, minimum and maximum values. With continuous data, the data range is limited for reserving the upper range for J1939 special and error codes.

The Data destination and Data destination number settings specify the target interface for the received data. The received data is always stored to a local variable assigned for each CAN receive message, but the Data destination needs to be configured for forwarding the data to the Modbus slave interfaces.

The screenshot displays the web interface for the AXIOMATIC ModbusRTU - ModbusTCP/IP Converter. The browser address bar shows the URL `192.168.1.20/can_rx_settings.shtml`. The page title is "AXIOMATIC Global Electronic Solutions ModbusRTU - ModbusTCP/IP Converter".

The interface includes a navigation menu on the left with the following items:

- Home
- Main Settings
- CAN RX Settings
- CAN TX Settings
- Modbus Slave Settings
- Modbus Master Settings
- Diagnostics Routing Settings
- Settings
- Upload/Download

The main content area is titled "CAN SETTINGS" and contains the following sections:

- CAN SETTINGS**: Includes buttons for "Save Settings", "Discard Changes", and "Set Defaults".
- CAN Receive Message Select**: Includes "Next", "Previous", and "Jump to" (with a value of 0) buttons.
- CAN Receive Message Settings**: A form for configuring a specific CAN Rx message (CAN Rx #0). The settings are as follows:
 - Message enabled: Yes
 - PGN: 0xFF00
 - Timeout: 0
 - Source address: 0
 - Check source address: No
 - Data type: Discrete
 - Data width: 8
 - Data byte index: 0
 - Data bit index: 0
 - Data resolution: 1.00
 - Data offset: 0.00
 - Data minimum: 0.00
 - Data maximum: 1.00
 - Data destination: Modbus RTU Discrete Input
 - Data destination number: 2
 - Allow TP: Yes

<configured ip>/can_tx_settings.shtml

Each of the CAN transmit messages support several signals for sending out received data. The transmit messages support the same 'Discrete' and 'Continuous' data types with same characteristics than the CAN receive messages do.

Please remember to save the settings before selecting a new transmit message or transmit signal. In case the values are not saved, the modifications are lost when a new message or signal is selected.

The screenshot displays the web interface for the AXIOMATIC ModbusRTU - ModbusTCP/IP Converter. The browser address bar shows the URL `192.168.1.20/can_tx_settings.shtml`. The page features a navigation menu on the left with links for Home, Main Settings, CAN RX Settings, CAN TX Settings, Modbus Slave Settings, Modbus Master Settings, Diagnostics Routing Settings, and Upload/Download. The main content area is titled "CAN SETTINGS" and includes a "Save Settings" button, a "Discard Changes" button, and a "Set Defaults" button. Below this is the "CAN Transmit Message Select" section with "Next", "Previous", and "Jump to" (0) buttons. The "CAN Transmit Message Settings" section for "CAN Tx #0" includes fields for "Message enabled" (Yes), "PGN" (0xFF81), "TX interval" (2000), "Priority" (6), and "Destination address" (0). The "CAN Transmit Signal Select" section also has "Next", "Previous", and "Jump to" (0) buttons. The "CAN Transmit Signal Settings" section for "CAN Tx #0 Signal #0" includes a dropdown for "Signal data source" (CAN RX message), and fields for "Signal data number" (0), "Signal data type" (Discrete), "Signal data width" (16), "Signal data byte index" (4), "Signal data bit index" (0), "Signal data resolution" (1.00), "Signal data offset" (0.00), "Signal data minimum" (0.00), and "Signal data maximum" (1.00).

<configured ip>/modbus_settings.shtml

The RS485-MODBUS-ENET device supports Modbus RTU and Modbus TCP/IP slaves running on its RS485 and Ethernet ports, respectively. The number and start address for each of the Modbus slave's inputs, coils and registers can be specified.

Please note that the slave interface is enabled only if the Modbus master implementation is not running on that interface.

The Modbus TCP/IP node address is a "don't care", but the RTU slave interface will read in only the messages that are targeted to the configured Modbus node address.

The number of inputs, coils and registers have an upper limit and the web server will not accept values beyond the built-in maximum limit.

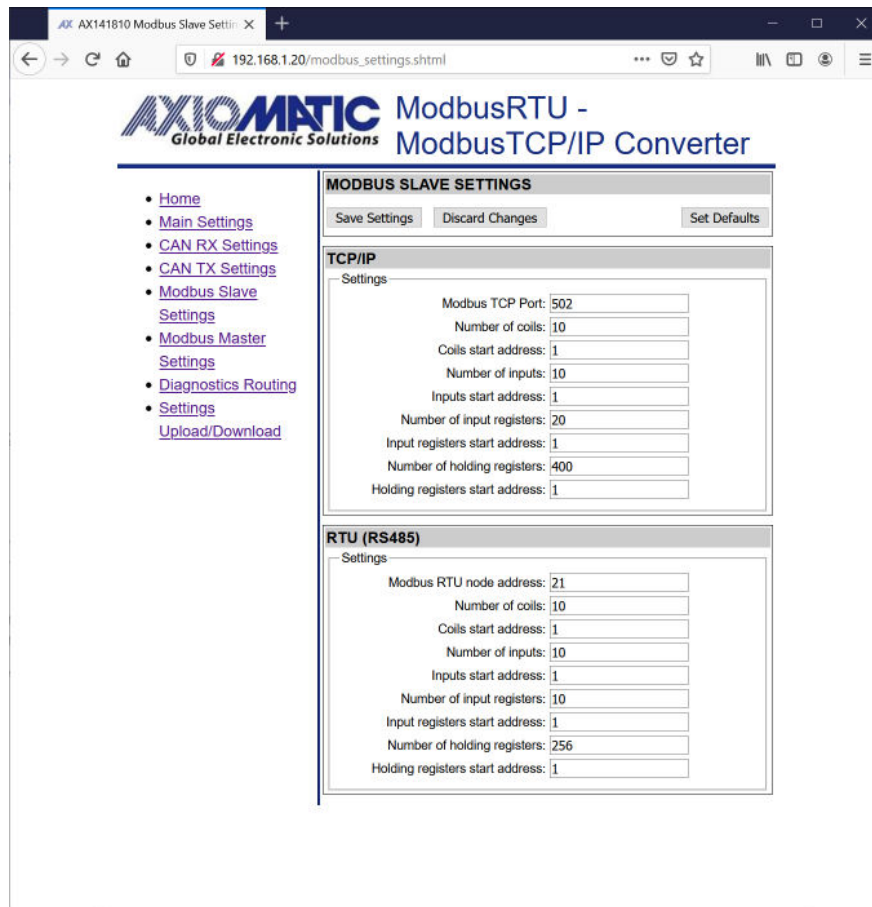

AXIOMATIC Global Electronic Solutions ModbusRTU - ModbusTCP/IP Converter

- [Home](#)
- [Main Settings](#)
- [CAN RX Settings](#)
- [CAN TX Settings](#)
- [Modbus Slave Settings](#)
- [Modbus Master Settings](#)
- [Diagnostics Routing](#)
- [Upload/Download](#)

MODBUS SLAVE SETTINGS

Save Settings Discard Changes Set Defaults

TCP/IP Settings

Modbus TCP Port:	502
Number of coils:	10
Coils start address:	1
Number of inputs:	10
Inputs start address:	1
Number of input registers:	20
Input registers start address:	1
Number of holding registers:	400
Holding registers start address:	1

RTU (RS485) Settings

Modbus RTU node address:	21
Number of coils:	10
Coils start address:	1
Number of inputs:	10
Inputs start address:	1
Number of input registers:	10
Input registers start address:	1
Number of holding registers:	256
Holding registers start address:	1

<configured ip>/modbus_master.shtml

The RS485-MODBUS-ENET device supports Modbus RTU and Modbus TCP/IP master running on its RS485 and Ethernet ports, respectively. The “Ethernet master enabled” and “RS485 master enabled” options need to be set to Yes for enabling the particular Modbus master.

Please note that enabling the Modbus master will disable the corresponding Modbus slave.

The Default target and Default source data routing options are the built-in variables for each Modbus master message definition. The CAN receive message data target configuration can access these variables directly if configured to do so on the CAN receive message configuration page.

The received Modbus data can be also sent directly to CAN bus by selecting the Direct CAN TX option for the Forward received data to setpoint. In this case, the Received data number specifies the J1939 PGN to use (the priority will default to 6 and the RS485-MODBUS-ENET’s J1939 address will be used as the source address for the direct transmit messages).

The screenshot shows a web browser window with the URL `192.168.1.20/modbus_master.shtml`. The page title is "AXIOMATIC Global Electronic Solutions ModbusRTU - ModbusTCP/IP Converter". A left-hand navigation menu includes links for Home, Main Settings, CAN RX Settings, CAN TX Settings, Modbus Slave Settings, Modbus Master Settings, Diagnostics Routing, and Upload/Download. The main content area is titled "MODBUS MASTER SETTINGS" and contains three sections: "MODBUS MASTER SETTINGS" with "Save Settings", "Discard Changes", and "Set Defaults" buttons; "MASTER ENABLE" with "Ethernet master enabled" and "RS485 master enabled" dropdown menus set to "No"; "MASTER MESSAGE SELECT" with "Next", "Previous", and "Jump to" (set to 0) buttons; and "Master Message" for "Message #0" with fields for "Message enabled" (No), "Device address" (0), "Function" (Not configured), "Register address" (0), "Number of registers" (0), "Interface to use" (Not configured), "Transmit interval" (0), "Forward received data to" (Default target), "Received data number" (0), "Data source for writes" (Default source), and "Source data number" (0).

<configured ip>/diagnostics_routing.shtml

J1939 DM1 diagnostics frames can be routed to Modbus slave interfaces (either RTU or TCP/IP) using the Diagnostics routing configuration.

The routing options include routing all received diagnostics to Modbus or only routing the specified ones.

In case specified diagnostics routing is configured, the SPN is the most important parameter to configure. The diagnostics are filtered mainly using this setting. In case needed, the FMI and SA values can be used for more detailed filtering of the received DM1 frames. The FMI and SA can be set to “don’t care” values (32 for FMI and 255 for SA) for accepting a wider range of SPNs.

The received DM1 data is forwarded to Modbus slave holding registers using this data layout.

	Holding register	
	<15:8>	<7:0>
<MB diag. start addr.>		SPN (MSBs)
<MB diag. start addr. + 1>	SPN (16 LSBs)	
<MB diag. start addr. + 2>	Lamp	FMI
<MB diag. start addr. + 3>	SA	OC

The screenshot shows a web browser window with the URL `192.168.1.20/diagnostics_routing.shtml`. The page title is "AXIOMATIC ModbusRTU - ModbusTCP/IP Converter". The AXIOMATIC logo is visible at the top left. A navigation menu on the left includes links for Home, Main Settings, CAN RX Settings, CAN TX Settings, Modbus Slave Settings, Modbus Master Settings, Diagnostics Routing Settings, and Upload/Download. The main content area is titled "DIAGNOSTIC ROUTING SETTINGS" and contains several sections:

- DIAGNOSTIC ROUTING SETTINGS:** Includes buttons for "Save Settings", "Discard Changes", and "Set Defaults".
- COMMON SETTINGS:** Includes a "Settings" section with "Diagnostics routing enabled" set to "Route specified SPN/FMI/SA", "Modbus diagnostics start address" set to "50", and "Target interface" set to "Modbus RTU slave".
- DIAGNOSTIC FORWARD ENTRY SELECT:** Includes "Next", "Previous", and "Jump to" (set to "0") buttons.
- LIST OF SPNs/FMIs/SAs TO FORWARD:** Includes a table with columns for "SPN/FMI/SA Entry #0", "SPN", "FMI", and "SA". The values shown are SPN: 0x64, FMI: 32, and SA: 255.

<configured ip>/settings_transfer.shtml

The settings can be downloaded from the RS485-MODBUS-ENET as a binary file. When a settings file is uploaded to the RS485-MODBUS-ENET, the settings are checked using a CRC32 checksum. In case the checksum isn't correct, the uploaded settings won't be stored to RS485-MODBUS-ENET's non-volatile memory.

The firmware v1.x requires a power cycle for applying the uploaded settings.

Please also note that AX141810 and AX141830 settings are not compatible with each other due to different number of supported routing functions.

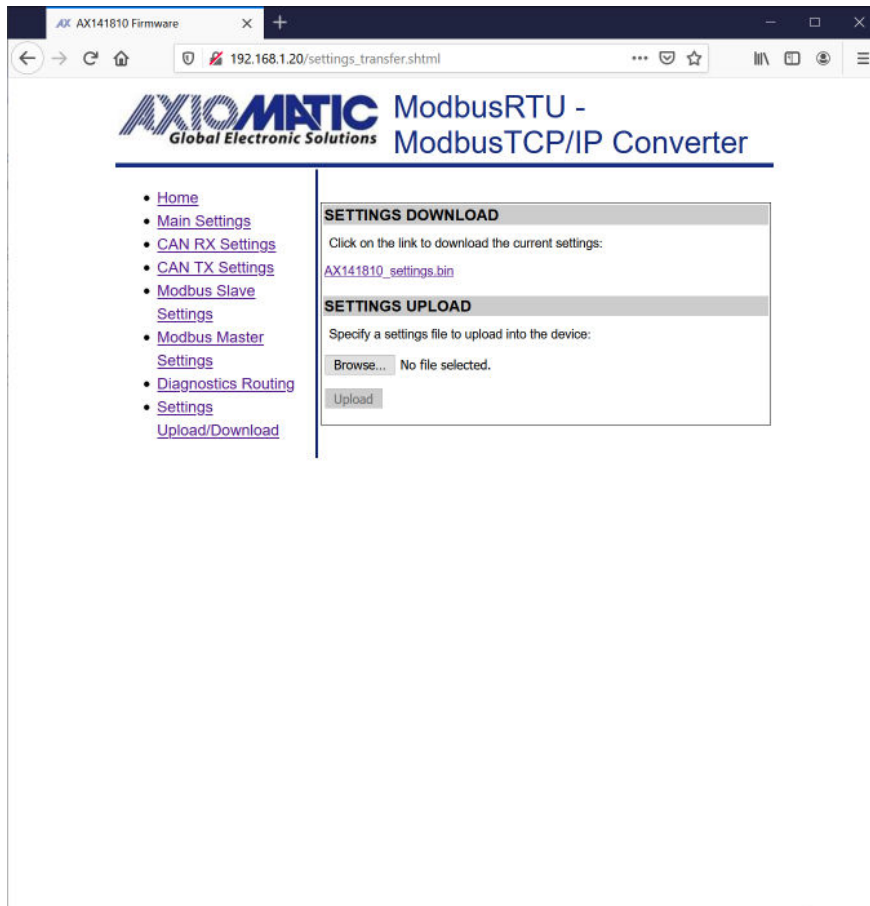

5. ECU SETPOINTS ACCESSED WITH THE AXIOMATIC ELECTRONIC ASSISTANT

5.1. J1939 Network Setpoints

“ECU Instance Number” and “ECU Address” setpoints and their effect are defined in section 3.2.

Name	Range	Default	Notes
ECU Instance Number	0-7	0x00	Per J1939-81
ECU Address	0-253	0x80	Preferred address for a self-configurable ECU

Table 2 – J1939 Setpoints

If non-default values for the “ECU Instance Number” or “ECU Address” are used, they will be mirrored during a setpoint file flashing, and will only take effect once the entire file has been downloaded to the unit. After the setpoint flashing is complete, the unit will claim the new address and/or re-claim the address with the new NAME. If these setpoints are changing, it is recommended to close and re-open the CAN connection on the Axiomatic EA after the file is loaded so that only the new NAME and address appear in the J1939 CAN Network ECU list.

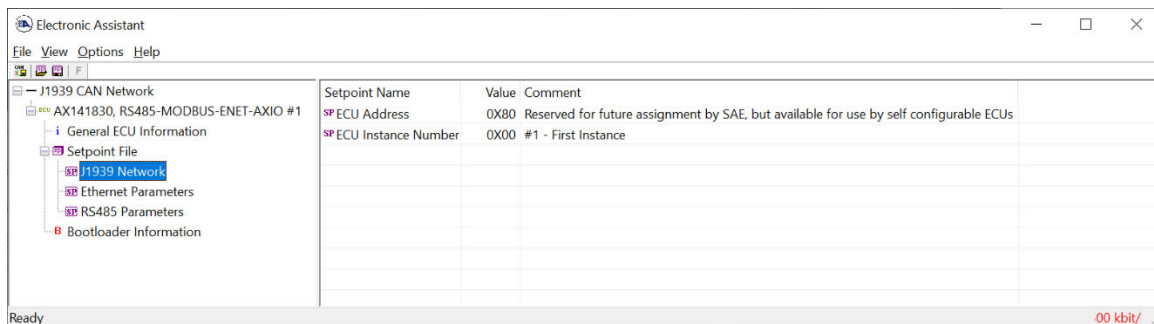

Figure 3 – Screen Capture of J1939 Setpoints

5.2. Ethernet Parameter Setpoints

The main Ethernet parameters can be configured using the Axiomatic EA for easier initial configuration of the RS485-MODBUS-ENET device. A power cycle is needed for taking the new settings in use.

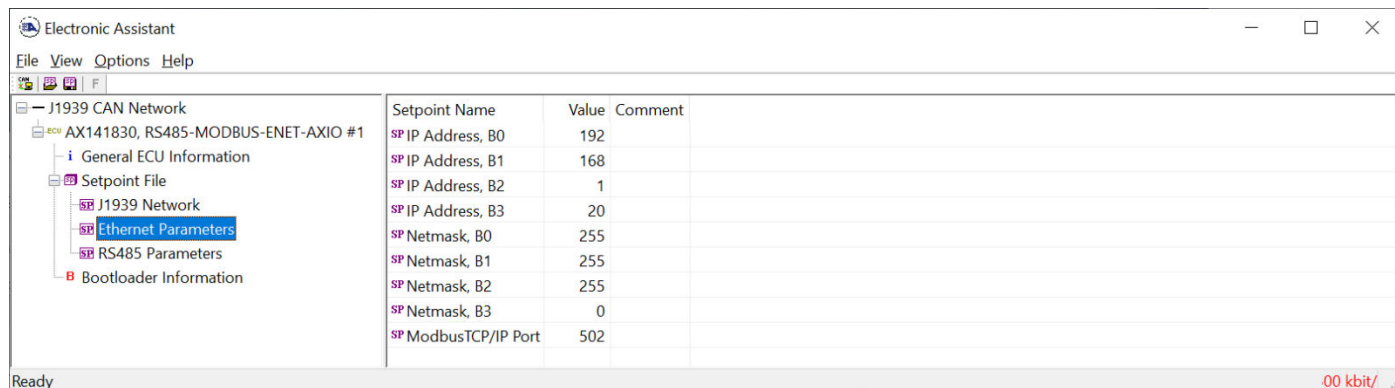

Figure 4 – Screen Capture of Ethernet Parameter Setpoints

Name	Range	Default	Notes
IP Address, B0	0...255	192	These settings define an IP address: 192.168.1.20
IP Address, B1	0...255	168	
IP Address, B2	0...255	1	
IP Address, B3	0...255	20	
Netmask, B0	0...255	255	These settings define a netmask 255.255.255.0
Netmask, B1	0...255	255	
Netmask, B2	0...255	255	
Netmask, B3	0...255	0	
ModbusTCP/IP Port	0...65535	502	The port for accessing the Modbus slave interface.

Table 3 – Ethernet Parameter Setpoints

5.3. RS485 Parameter Setpoints

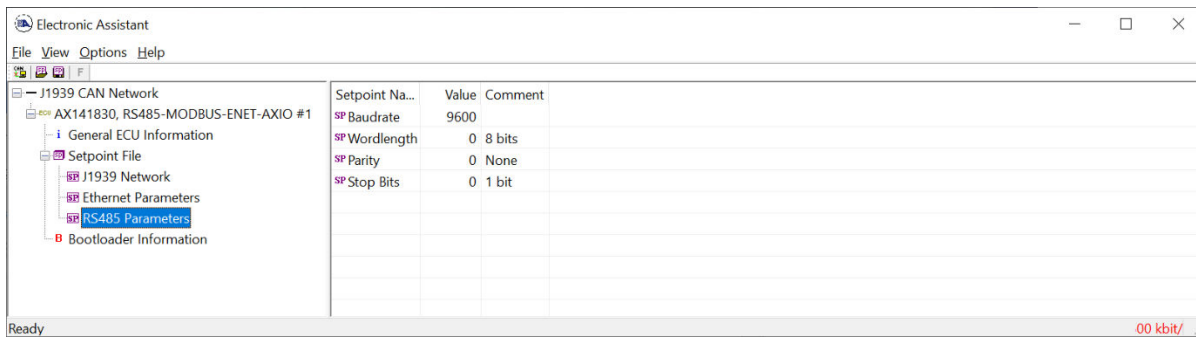

Figure 5 – Screen Capture of RS485 Parameter Setpoints

Name	Range	Default	Notes
Baudrate	0...256000	9600	The RS485 port baud rate to use.
Wordlength	0, 1	0 – 8 bits	Number of data bits to use, 8bits or 9bits.
Parity	0, 1, 2	0 – None	Parity: None, even, odd.
Stop bits	0, 1	0 – 1 bit	Number of stop bits, 1 bit or 2 bits.

Table 4 – RS485 Parameter Setpoints

6. REFLASHING OVER CAN WITH THE AXIOMATIC EA BOOTLOADER

The AX141810/AX141830 can be upgraded with new application firmware using the **Bootloader Information** section. This section details the simple step-by-step instructions to upload new firmware provided by Axiomatic onto the unit via CAN, without requiring it to be disconnected from the J1939 network.

Note: To upgrade the firmware use Axiomatic Electronic Assistant V<TBD> or higher.

1. When the Axiomatic EA first connects to the ECU, the **Bootloader Information** section will display the following information.

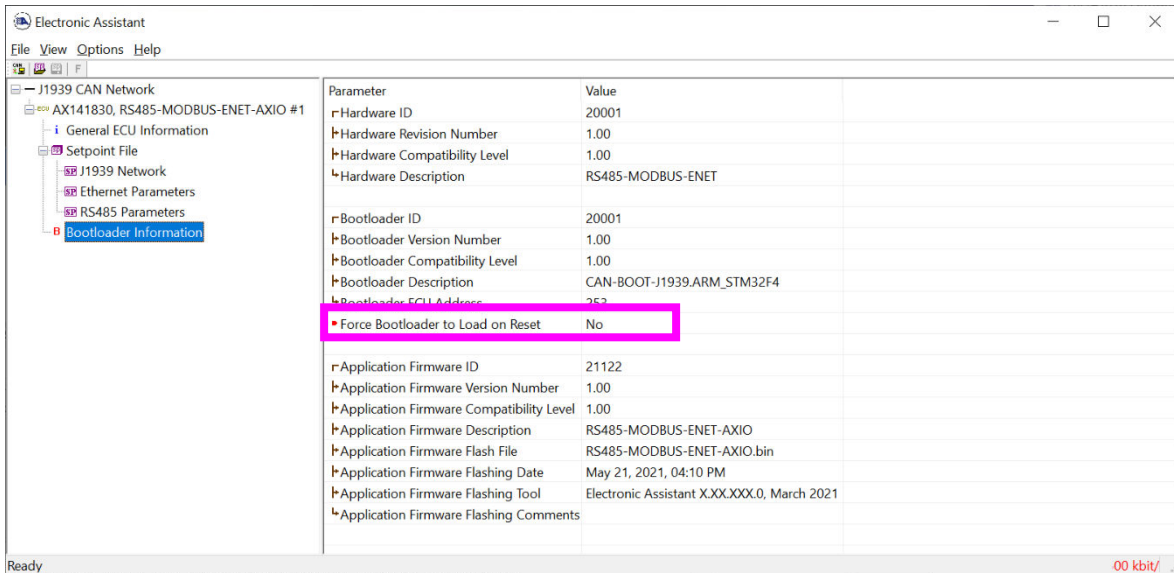

2. To use the bootloader to upgrade the firmware running on the ECU, change the variable “**Force Bootloader To Load on Reset**” to Yes.

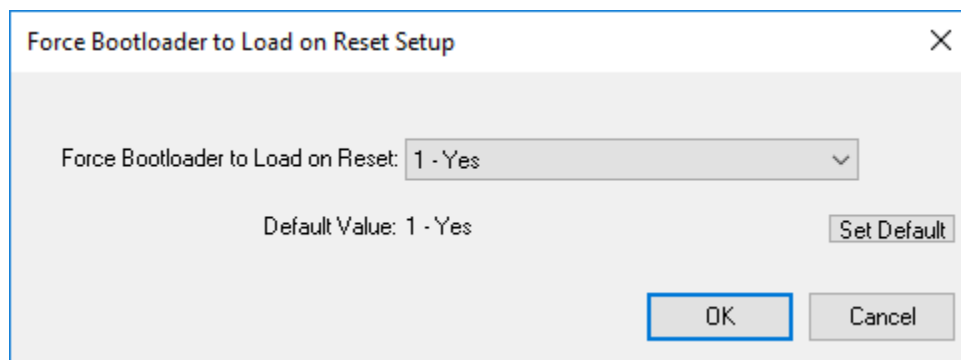

3. When the prompt box asks if you want to reset the ECU, select Yes.

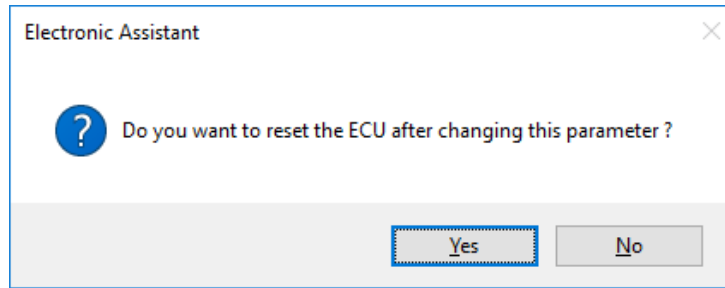

4. Upon reset, the ECU will no longer show up on the J1939 network as an AX142100 but rather as **J1939 Bootloader #1**.

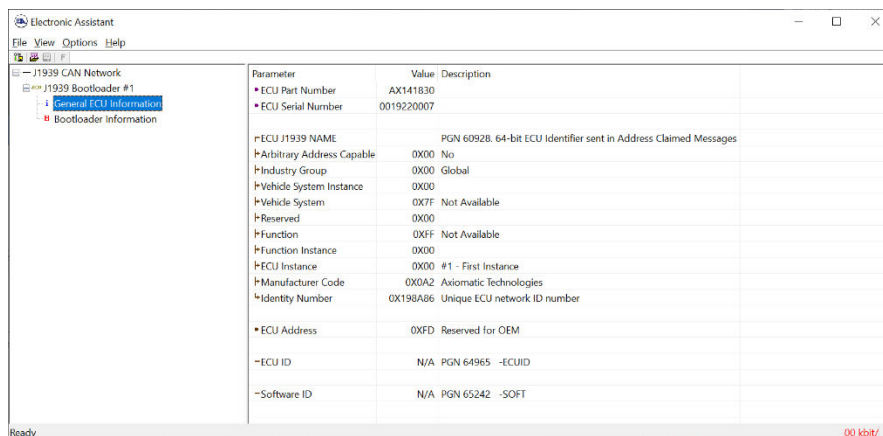
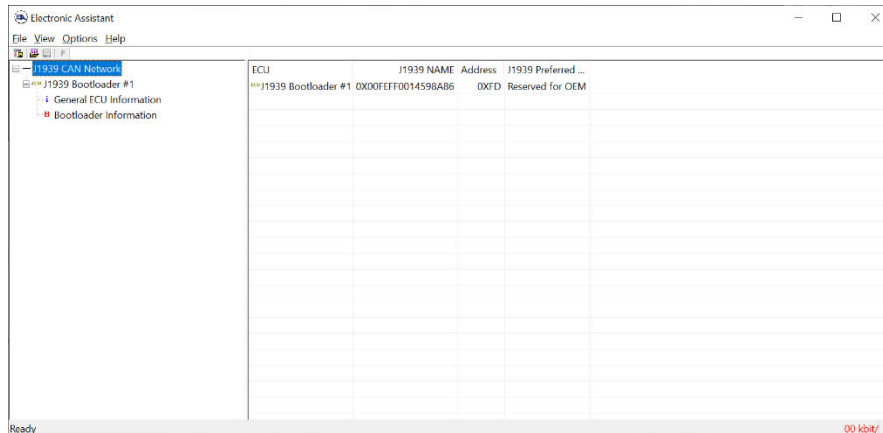

Note that the bootloader is NOT Arbitrary Address Capable. This means that if you want to have multiple bootloaders running simultaneously (not recommended) you would have to manually change the address for each one before activating the next, or there will be address conflicts. And only one ECU would show up as the bootloader. Once the 'active' bootloader returns to regular functionality, the other ECU(s) would have to be power cycled to re-activate the bootloader feature.

- When the **Bootloader Information** section is selected, the same information is shown as when it was running the AX141810/AX141830 firmware, but in this case the **F**lashing feature has been enabled.

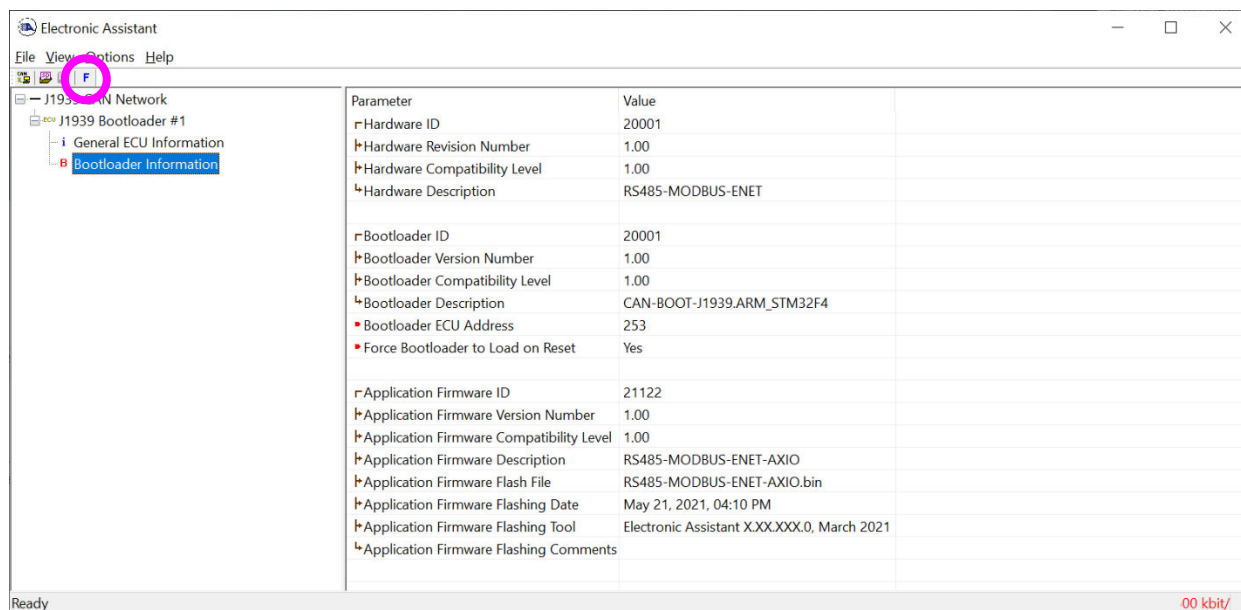

- Select the **F**lashing button and navigate to where you had saved the **AF-20149-x.xx.bin/AF-21122-x.xx.bin** file sent from Axiomatic. (Note: only binary (.bin) files can be flashed using the Axiomatic EA tool.)
- Once the Flash Application Firmware window opens, you can enter comments such as “Firmware upgraded by [Name]” if you so desire. This is not required, and you can leave the field blank if you do not want to use it.

Note: You do not have to date/time-stamp the file, as the Axiomatic EA tool automatically does this when you upload the new firmware.

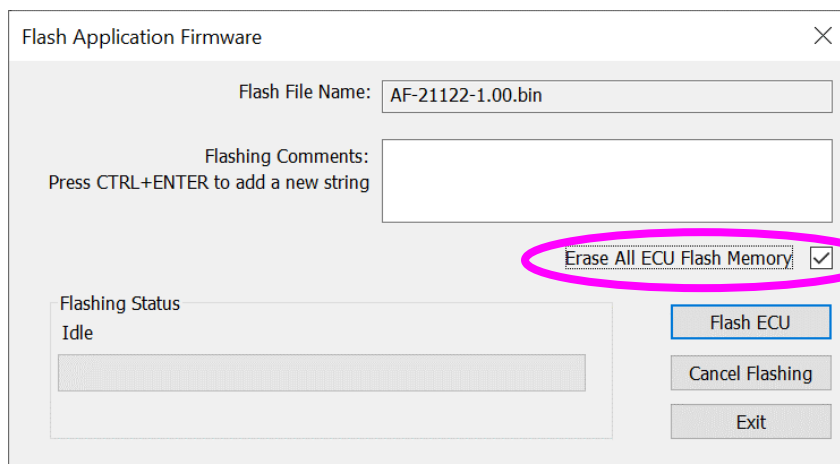



NOTE: Selecting the “Erase All ECU Flash Memory” option will **erase ALL configuration data stored in non-volatile EEPROM and Flash.** This means that any configuration of the setpoints that might have been done to the ECU using a web browser or Axiomatic Electronic Assistant will be reset to their factory defaults. In case the controller contains custom settings, those settings need to be saved to PC before reflashing.

A progress bar will show how much of the firmware has been sent as the upload progresses. The more traffic there is on the J1939 network, the longer the upload process will take.

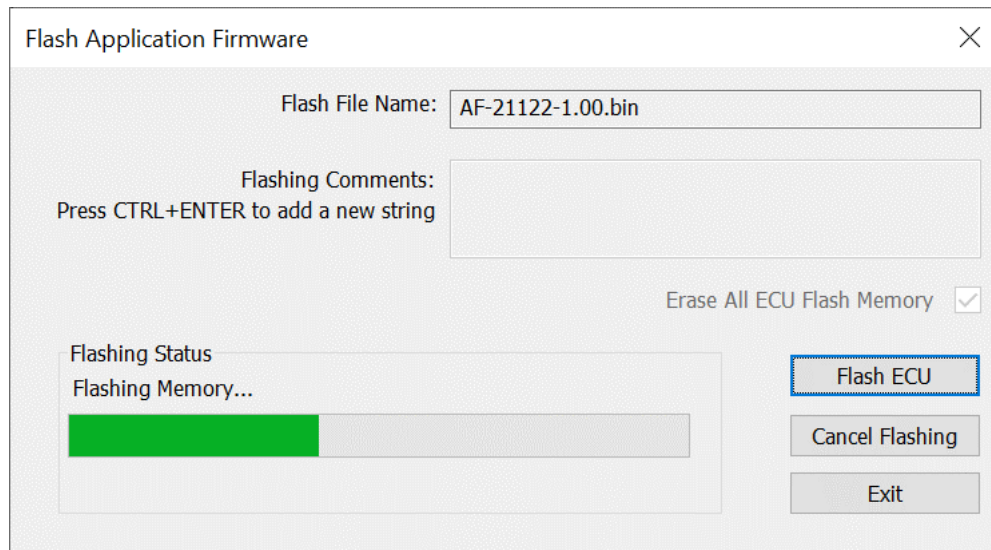

Once the firmware has finished uploading, a message will pop up indicating the successful operation. If you select to reset the ECU, the new version of the AX141810/AX141830 application will start running, and the ECU will be identified as such by the Axiomatic EA. Otherwise, the next time the ECU is power-cycled, the AX141810/AX141830 application will run rather than the bootloader function.

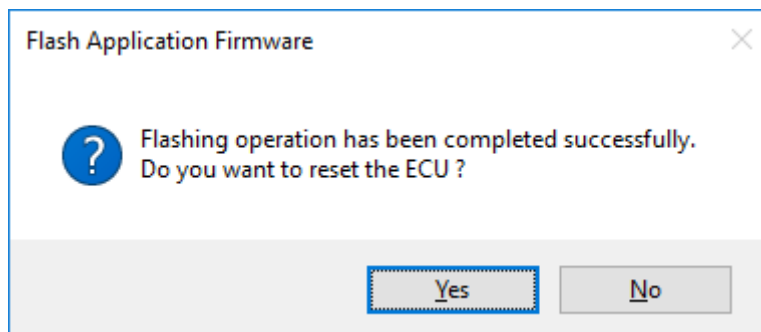



Note: If at any time during the upload the process is interrupted, the data is corrupted (bad checksum) or for any other reason the new firmware is not correct, i.e. bootloader detects that the file loaded was not designed to run on the hardware platform, the bad or corrupted application will not run. Rather, when the ECU is reset or power-cycled the **J1939 Bootloader** will continue to be the default application until valid firmware has been successfully uploaded into the unit.

APPENDIX A - TECHNICAL SPECIFICATION

Specifications are indicative and subject to change. Actual performance will vary depending on the application and operating conditions. Users should satisfy themselves that the product is suitable for use in the intended application. All our products carry a limited warranty against defects in material and workmanship. Please refer to our Warranty, Application Approvals/Limitations and Return Materials Process as described on <https://www.axiomatic.com/service/>.

Power

Power Supply Input - Nominal	12 V or 24 Vdc nominal; 9...36 Vdc
Under-voltage Protection	Hardware shuts down at 6Vdc.
Surge Protection	95 Vdc
Over-voltage Protection	Hardware shuts down at 40Vdc.
Reverse Polarity Protection	Provided up to -40V

Functionality

Conversion Platform	The Protocol Converter supports conversion logic for bidirectional data exchange between Ethernet (Modbus TCP/IP), RS-485 (Modbus RTU) and SAE J1939 CAN networks. The actual conversion logic setup is highly application specific, the AX141810 ships with no configuration to allow the user to set up the parameters.
Ethernet	1 port 10/100 Mbit Ethernet compliant 10BASE-T, 100BASE-Tx (auto-negotiation and full-duplex supported) Auto-MDIX Modbus TCP/IP
RS-485	Modbus RTU Isolated Single half-duplex RS-485 port provided Baud rate: Configurable (75Bit/s to 256 kBit/s)
CAN	SAE J1939 Isolated Baud rate: Default 250 kBit/s Baud rate: auto baud rate capable, 250 kBit/s / 500kBit/s / 1Mbit/s

General Specifications

Memory	STM32F407VGT7 32-bit, 1Mbyte Flash Program Memory
Quiescent Current Draw	62 mA @12 V; 32 mA @24 V
Isolation	CAN isolation: 330 Vrms; RS-485 isolation: 300 Vrms
Operating Conditions	-40 to 65°C (-40 to 149°F)
Enclosure and Dimensions	Aluminum enclosure, Integral TE Deutsch type connector, Encapsulation Refer to dimensional drawing in Installation Instructions.
Electrical Connections	12-pin Integral connector (equivalent TE Deutsch P/N: DT15-12PA) A mating plug kit is available as Axiomatic P/N: AX070105 . Refer to pinout in Installation Instructions
Weight	0.71 lbs. (0.32 kg)
Protection Rating	IP67; Unit is encapsulated within the housing.
Vibration and Shock	4 g IEC publication 60068-2-6, Test Fc
Installation	Mounting holes sized for #10 or M4.5 bolts. The bolt length will be determined by the end-user's mounting plate thickness. The mounting flange of the controller is 0.19 inches (4.75 mm) thick. If the module is mounted without an enclosure, it should be mounted to reduce the likelihood of moisture entry. Install the unit with appropriate space available for servicing and for adequate wire harness access (6 inches or 15 cm) and strain relief (12 inches or 30 cm). The CAN wiring is considered intrinsically safe. The power wires are not considered intrinsically safe and so in hazardous locations, they need to be located in conduit or conduit trays at all times. The module must be mounted in an enclosure in hazardous locations for this purpose. All field wiring should be suitable for the operating temperature range of the module. All chassis grounding should go to a single ground point designated for the machine and all related equipment.
User Interface – SAE J1939 models	Parameters are configurable using a web browser. The Axiomatic Electronic Assistant KIT, P/Ns: AX070502 or AX070506K can be used for firmware updates and for configuring Device IP address, netmask and Modbus port.

OUR PRODUCTS

AC/DC Power Supplies
Actuator Controls/Interfaces
Automotive Ethernet Interfaces
Battery Chargers
CAN Controls, Routers, Repeaters
CAN/WiFi, CAN/Bluetooth, Routers
Current/Voltage/PWM Converters
DC/DC Power Converters
Engine Temperature Scanners
Ethernet/CAN Converters,
Gateways, Switches
Fan Drive Controllers
Gateways, CAN/Modbus, RS-232
Gyroscopes, Inclinometers
Hydraulic Valve Controllers
Inclinometers, Triaxial
I/O Controls
LVDT Signal Converters
Machine Controls
Modbus, RS-422, RS-485 Controls
Motor Controls, Inverters
Power Supplies, DC/DC, AC/DC
PWM Signal Converters/Isolators
Resolver Signal Conditioners
Service Tools
Signal Conditioners, Converters
Strain Gauge CAN Controls
Surge Suppressors

OUR COMPANY

Axiomatic provides electronic machine control components to the off-highway, commercial vehicle, electric vehicle, power generator set, material handling, renewable energy and industrial OEM markets. ***We innovate with engineered and off-the-shelf machine controls that add value for our customers.***

QUALITY DESIGN AND MANUFACTURING

We have an ISO9001:2015 registered design/manufacturing facility in Canada.

WARRANTY, APPLICATION APPROVALS/LIMITATIONS

Axiomatic Technologies Corporation reserves the right to make corrections, modifications, enhancements, improvements, and other changes to its products and services at any time and to discontinue any product or service without notice. Customers should obtain the latest relevant information before placing orders and should verify that such information is current and complete. Users should satisfy themselves that the product is suitable for use in the intended application. All our products carry a limited warranty against defects in material and workmanship. Please refer to our Warranty, Application Approvals/Limitations and Return Materials Process at <https://www.axiomatic.com/service/>.

COMPLIANCE

Product compliance details can be found in the product literature and/or on axiomatic.com. Any inquiries should be sent to sales@axiomatic.com.

SAFE USE

All products should be serviced by Axiomatic. Do not open the product and perform the service yourself.



This product can expose you to chemicals which are known in the State of California, USA to cause cancer and reproductive harm. For more information go to www.P65Warnings.ca.gov.

SERVICE

All products to be returned to Axiomatic require a Return Materials Authorization Number (RMA#) from sales@axiomatic.com. Please provide the following information when requesting an RMA number:

- Serial number, part number
- Runtime hours, description of problem
- Wiring set up diagram, application and other comments as needed

DISPOSAL

Axiomatic products are electronic waste. Please follow your local environmental waste and recycling laws, regulations and policies for safe disposal or recycling of electronic waste.

CONTACTS

Axiomatic Technologies Corporation
1445 Courtneypark Drive E.
Mississauga, ON
CANADA L5T 2E3
TEL: +1 905 602 9270
FAX: +1 905 602 9279
www.axiomatic.com
sales@axiomatic.com

Axiomatic Technologies Oy
Höytämöntie 6
33880 Lempäälä
FINLAND
TEL: +358 103 375 750
www.axiomatic.com
salesfinland@axiomatic.com