

Technical Datasheet #TDAXRTD8CO
RTD Scanner
8 RTD Channels
CANopen®
RS-232
P/N: AXRTD8CO

Description: The RTD Scanner monitors 8 Platinum RTD inputs with 2, 3, or 4 wire configurations. The temperature information is provided to the engine control system over CANopen®. Integral diagnostics determine RTD integrity. RTD inputs are isolated from the CAN communications and power supply. Active channels are scanned sequentially (1 to 8) with approximately 100 ms between readings. Temperature is measured in °C, with a 0.1°C resolution. The scanner will send temperatures with +/- 1°C accuracy. The average temperature of all the active channels, or all channels from a block of 4, can be broadcasted to the network. The scanner can flag low temperature warnings, high temperature warnings, or high temperature shutdowns to the engine control system. It will also detect and indicate open circuits on the sensor wires. The power supply was designed for nominal inputs of 12V or 24V and is operational from 9-32Vdc. CAN communications are via an isolated CAN interface. Using commercially available CANopen® service tools, the operator can configure the controller to suit a wide variety of applications using SDO object access, per CiA DS-301. An EDS file is provided. Settings are saved to non-volatile memory upon command. A SAE J1939 model is available.



The RTD Scanner features rugged packaging and watertight Deutsch IPD connectors for an IP67 rating. The module is UL recognized for UL508 (FTPM2) – Controls for Stationary Engine Driven Assemblies and has a cUL recognition as well. The control carries a CE mark for the EMC and RoHS Directives. The AXRTD8 meets the environmental, EMC and vibration requirements of generator set applications in marine installations and has type approvals from several marine societies (LR, DNV, ABS, etc.).

Applications: Power generator sets and control systems for industrial engines

Ordering Part Numbers:

8 RTD Scanner, CANopen® P/N: AXRTD8CO EDS file and User Manual #UMAXRTD8CO: Available on our website www.axiomatic.com . Go to the log-in tab, enter the password and download. The password is available from sales@axiomatic.com .	
Mating Plug Kit P/N: AX070200 This kit includes the following items. These items are also available from a local Deutsch IPD distributor. <i>NB. The sealing plugs are only needed in cases where not all of the 40 pins are used.</i>	
Deutsch IPD P/N:	Description:
0462-201-16141	48 16AWG SOCKETS SOLID 16-20AWG WIRE 6mm
114017	24 SEALING PLUGS SIZE 12-16 CAVITIES 12-18 AWG
DRC16-40S	40-PIN PLUG, No Key
DT06-08SA	DT SERIES PLUG 8 CONTACT
W8S	WEDGELOCK FOR DT 8 PIN PLUG
A crimping tool from Deutsch IPD is required to connect wiring to the sockets, P/N: HDT 48-00 or equivalent (not supplied).	

The CANopen® 8 Channel RTD Scanner is compliant with the following CiA profiles.

- CiA DS-301 V4.1 – *CANopen® Application Layer and Communication Profile* (CAN in Automation 2005)
- CiA DS-305 V2.0 – *Layer Setting Service (LSS) and Protocols* (CAN in Automation 2006)
- CiA DS-404 V1.2 – *CANopen® profile for Measurement Devices and Closed Loop Controllers* (CAN in Automation 2002)

The documents are available from the CAN in Automation e.V. website <http://www.can-cia.org>.

Block Diagram

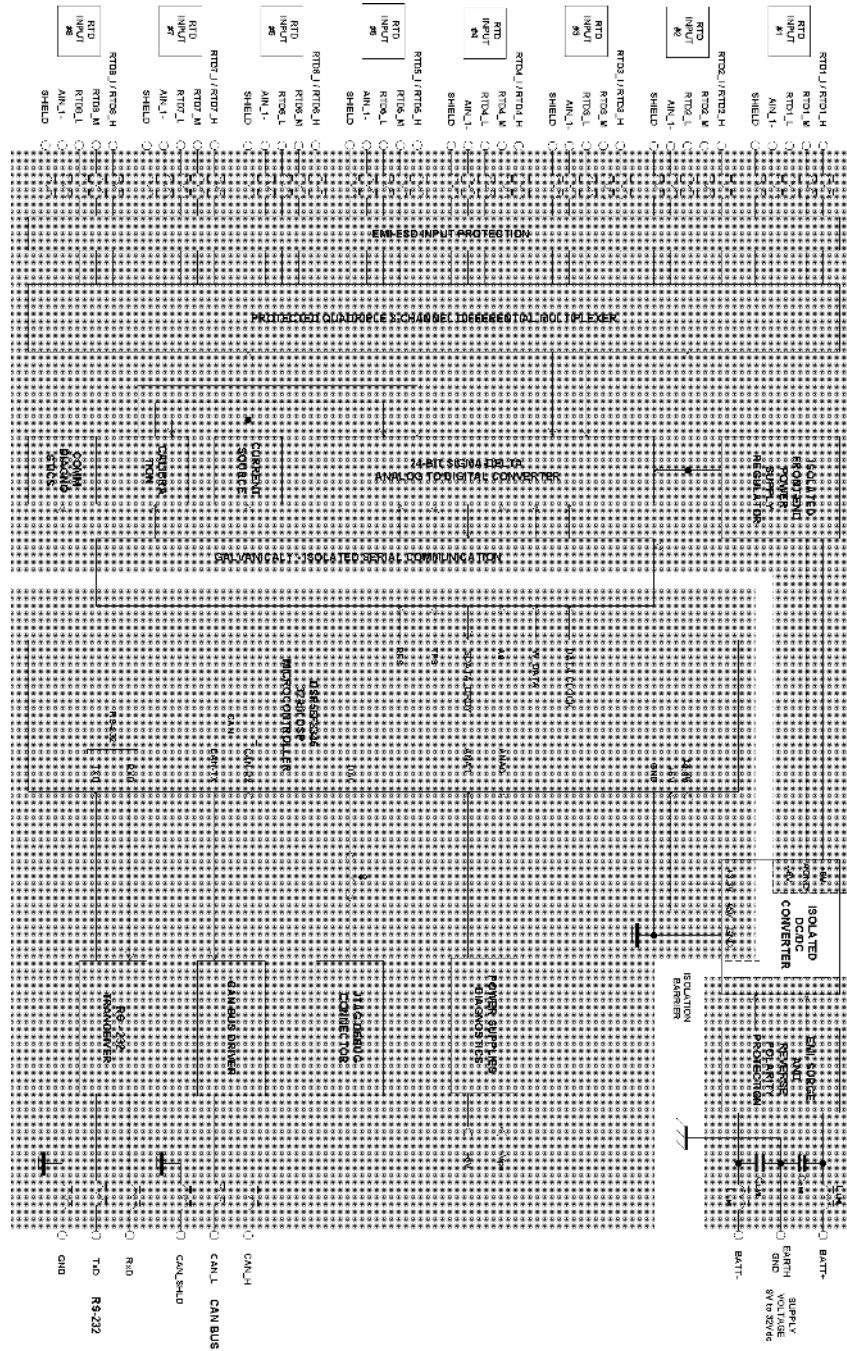

Technical Specifications:

Inputs

Power Supply Input	12V or 24VDC nominal (9...32 VDC power supply range)
Supply Current	200 mA at 12 V Typical 100 mA at 24 V Typical Inrush does not exceed 800 mA.
Protection	Reverse polarity protection is provided. Power supply input section protects against transient surges and short circuits and is isolated from RTD inputs
RTD Types	Up to 8 channels, independently configurable for 2, 3 or 4 wire RTDs.
RTD Inputs	Each channel independently supports specific sensors IEC 0.00385, JIS 0.003916, US 0.003902, Legacy 0.003920, SAMA 0.003923. A user defined coefficient would enable custom Callendar-Van Dusen constants to be set for sensors not listed above. The device accepts inputs within the following range of 10 - 350 Ohms. Accuracy: +/- 1°C typical at ambient temperature Resolution: 0.001°C Isolation voltage is 1500 Vac (rms) or 2550V for 1 sec.
Scan Rate	100ms per channel, total sweep time maximum 900 ms
Common Mode Readings	Input range +/- 4V maximum Rejection is 100db at 5Vp-p (50-60Hz)
Thermal Drift	150 ppm/°C of span (maximum)
Isolation	Digital isolation is 500VDC from input to ground. Three way isolation is provided for the CAN line, inputs and power supply
Averaging	Available on Bank 1 (RTD1-RTD4), Bank 2 (RTD5-RTD8) and Total (All)
Protection	Open circuit detection Frozen data detection Over or under temperature detection High temperature shutdown detection

Communication

CAN	1 CAN 2.0Bport, protocol CiA CANopen ® By default, the RTD Scanner transmits the process value (object \$7130) according to the device profile in CiA Standard DS-404
Network Termination	According to the CAN standard, it is necessary to terminate the network with external termination resistors. The resistors are 120 Ohm, 0.25W minimum, metal film or similar type. They should be placed between CAN_H and CAN_L terminals at both ends of the network.
RS-232	1 RS-232 port is available for debugging purposes. ASCII Text Format, 115200 Baud Rate Data – 8 bit, Parity – None, Stop – 1 bit. Flow Control – Xon/Xoff. Short circuit protection to ground.

General Specifications

Microprocessor	MC56F8366, 16-bit, 512 kByte flash program memory
Control Logic	User programmable functionality using SDO object access, per CiA DS-301 <ul style="list-style-type: none"> Units are pre-configured with default values at the factory. Refer to the user manual # UMAXRTD8CO. The default bit-rate is 125 kbit/s. Other bit-rates can be selected using Layer Setting Services. Module starts in pre-operational mode. Saved parameter values are retained when the modules are de-energized.
User Interface	.EDS provided to interface to standard CANopen ® tools
Diagnostics	Available on mandatory object \$1003, Pre-Defined Error Field Additional information for diagnostic and testing purposes can be obtained using the RS-232 port and Tera Term.
UL and cUL Compliance	UL508 (April 2010) (FTPM2) – Controls for Stationary Engine Driven Assemblies cUL C22.2 No. 14-10 (2010)
CE Compliance	2004/108/EC (EMC Directive) 2011/65/EU (RoHS Directive)
Vibration	11.48 G for a device rigidly mounted to a generator housing <i>The marine type approval process tested to 4,0 G per IEC 60068-2-6, Test Fc.</i>
Marine Type Approval	Lloyd's Register, DNV, ABS, RINA, GL, BV, CCS, IRS, RS <i>The AXRTD8CO meets the environmental, EMC and vibration requirements of generator set applications in marine installations.</i>
Operating Temperature Range	-40 to 85 °C (-40 to 185 °F)
Storage Temperature Range	-50 to 120 °C (-58 to 248 °F)
Humidity	Protected against 95% humidity non-condensing, 30 °C to 60 °C
Protection	IP67, Pollution Degree 3 per UL508 <i>The marine type approval process tested to IP56.</i>
Weight	2.2 lbs. (1.00 kg)
Enclosure	Rugged aluminum housing, stainless steel end plates, neoprene gaskets 145.30 x 149.00 x 73.00 mm (5.72 x 5.86 x 2.87") L x W x H Connectors, Deutsch IPD P/N: 1 8-pin DT13-08PA, 1 40-pin DRC13-40PA Can be mounted directly on the power generator set or remotely Suitable for moist, high shock, vibrating and non-hazardous environments

Dimensional Drawing

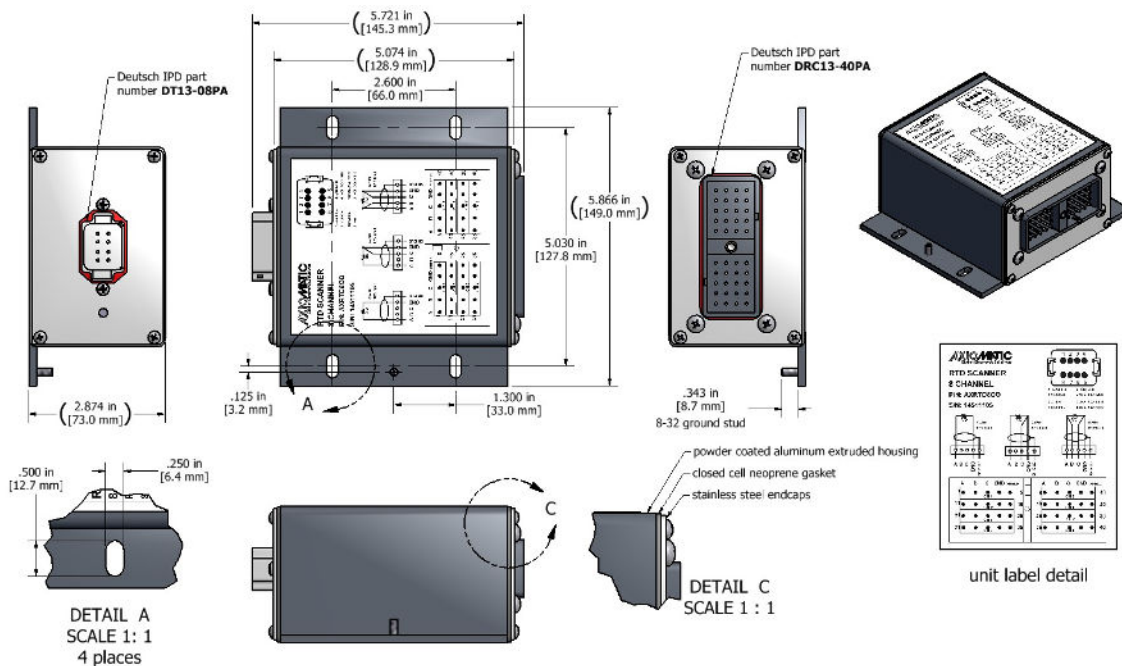

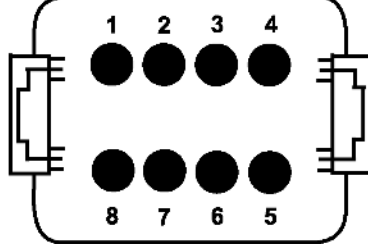
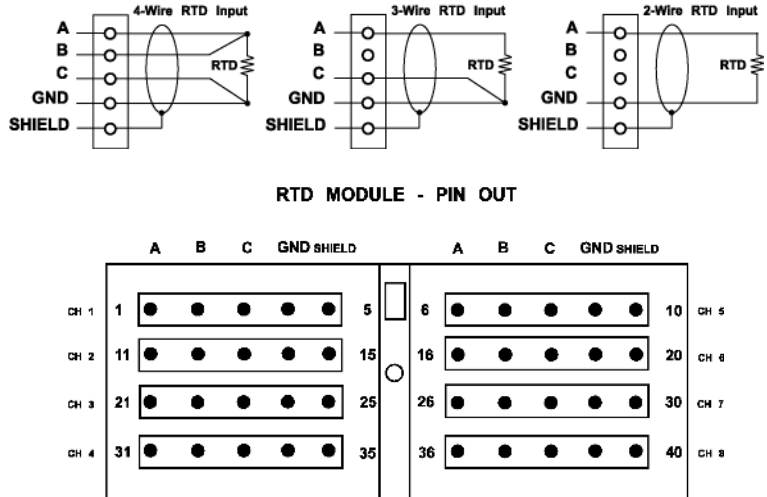
Electrical Pin Out – Power and CAN	 <p style="text-align: center;">FRONT VIEW MODULE MOUNTED CONNECTOR DEUTSCH P/N: DT13-08PA</p> <p style="text-align: center;">1 = PWR+ 5 = SHIELD 2 = CAN-H 6 = RS-232 GND 3 = CAN-L 7 = RS-232 TXD 4 = PWR- 8 = RS-232 RXD</p> <p style="text-align: center;">(Mating plug is DT06-08SA with wedgelock W8S and sockets 0462-201-16141.)</p>												
Electrical Pin Out - RTD	 <p style="text-align: center;">RTD MODULE - PIN OUT</p> <p style="text-align: center;">FRONT VIEW OF MODULE MOUNTED CONNECTOR</p> <p style="text-align: right;"><small>Nov. 2003 AJW</small></p> <p>Mating Connector Part Number: Deutsch IPD p/n DRC16-40SA or DRC18-40SA with sockets 0462-201-16141</p>												
Mating Sockets	<p>Mating Plug Kit P/N: AX070200 This kit includes the following items. These items are also available from a local Deutsch IPD distributor. <i>NB. The sealing plugs are only needed in cases where not all of the 40 pins are used.</i></p> <table border="1" data-bbox="625 1459 1396 1701"> <thead> <tr> <th>Deutsch IPD P/N:</th> <th>Description:</th> </tr> </thead> <tbody> <tr> <td>0462-201-16141</td> <td>48 16AWG SOCKETS SOLID 16-20AWG WIRE 6mm</td> </tr> <tr> <td>114017</td> <td>24 SEALING PLUGS SIZE 12-16 CAVITIES 12-18 AWG</td> </tr> <tr> <td>DRC16-40S</td> <td>40-PIN PLUG, No Key</td> </tr> <tr> <td>DT06-08SA</td> <td>DT SERIES PLUG 8 CONTACT</td> </tr> <tr> <td>W8S</td> <td>WEDGELOCK FOR DT 8 PIN PLUG</td> </tr> </tbody> </table> <p>A crimping tool from Deutsch IPD is required to connect wiring to the sockets, P/N: HDT 48-00 or equivalent (not supplied).</p>	Deutsch IPD P/N:	Description:	0462-201-16141	48 16AWG SOCKETS SOLID 16-20AWG WIRE 6mm	114017	24 SEALING PLUGS SIZE 12-16 CAVITIES 12-18 AWG	DRC16-40S	40-PIN PLUG, No Key	DT06-08SA	DT SERIES PLUG 8 CONTACT	W8S	WEDGELOCK FOR DT 8 PIN PLUG
Deutsch IPD P/N:	Description:												
0462-201-16141	48 16AWG SOCKETS SOLID 16-20AWG WIRE 6mm												
114017	24 SEALING PLUGS SIZE 12-16 CAVITIES 12-18 AWG												
DRC16-40S	40-PIN PLUG, No Key												
DT06-08SA	DT SERIES PLUG 8 CONTACT												
W8S	WEDGELOCK FOR DT 8 PIN PLUG												

Specifications are indicative and subject to change. Actual performance will vary depending on the application and operating conditions. Users should satisfy themselves that the product is suitable for use in the intended application. All our products carry a limited warranty against defects in material and workmanship. Please refer to our Warranty, Application Limitations & Return Materials Process as described on <https://www.axiomatic.com/service/>.

TDAXRTD8CO-04/09/2025