

4 Channel Strain Gauge CAN Controller CAN (SAE J1939)

P/N: AX200300

Features:

- 4 channels for inputs from 4-wire full bridge strain gauges:
 - +/- 19.5 mV to +/- 2.5 Vdc (selectable)
- 1 digital input, 1 analog/digital output
- 1 interlock (relay) output
- 12V, 24Vdc (nominal) power input
- 4 +5V excitation connections
- Wire break detection
- 1 CAN port (SAE J1939) with auto-baud-rate detection
- Rugged enclosure and connectors (TE Deutsch equivalent)
- Standard control logic
- User configurable with Axiomatic Electronic Assistant



Description: The 4 Channel Strain Gauge CAN controller accepts up to four 4-wire strain gauge connections. The input range is user selectable from +/- 19.5 mV to +/- 2.5 Vdc. It interfaces with the machine's CAN network (SAE J1939). The measurement rate is configurable. Standard embedded software is provided. Rugged IP67 rated enclosure and a power supply input of 12Vdc or 24Vdc nominal suits applications in the harsh environment of mobile equipment with on-board battery power. All setpoints are user configurable using the Axiomatic Electronic Assistant.

Applications:

- Construction equipment, lift equipment and cranes

Ordering Part Numbers:

Controller, SAE J1939, auto-baud-rate detect: **AX200300**

Controller, CANopen@: **AX200301**

Accessories:

PL-DTM06-12SA-12SB Mating Plug Kit (1 DTM06-12S, DTM06-12SB, 2 W12S, 24 contacts)

The Axiomatic Electronic Assistant Configuration KIT: **AX070502**, or **AX070506K**

Control Logic:

The AX200300 is a highly programmable controller - allowing the user to configure it for their application. Its input, logical and mathematical function blocks allow the controller to support a wide variety of load cells to fit customer's various applications.

All inputs and logical function blocks on the unit are inherently independent from one another but can be programmed to interact in a large number of ways. The logical function blocks (software) are shown below.

The various function blocks supported by the module have configurable setpoints using Axiomatic's Service Tool, the Electronic Assistant (EA).

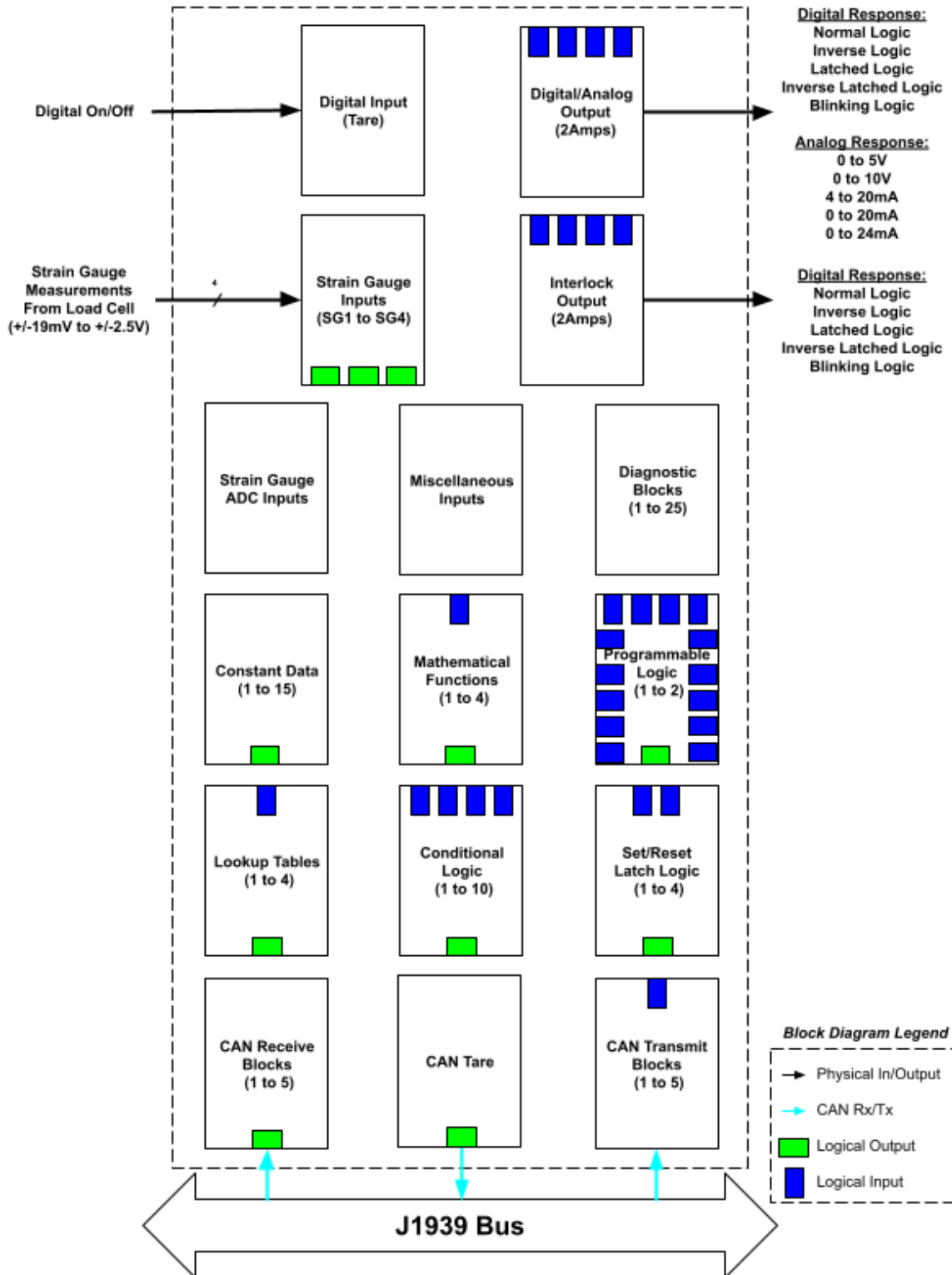

BLOCK DIAGRAM:

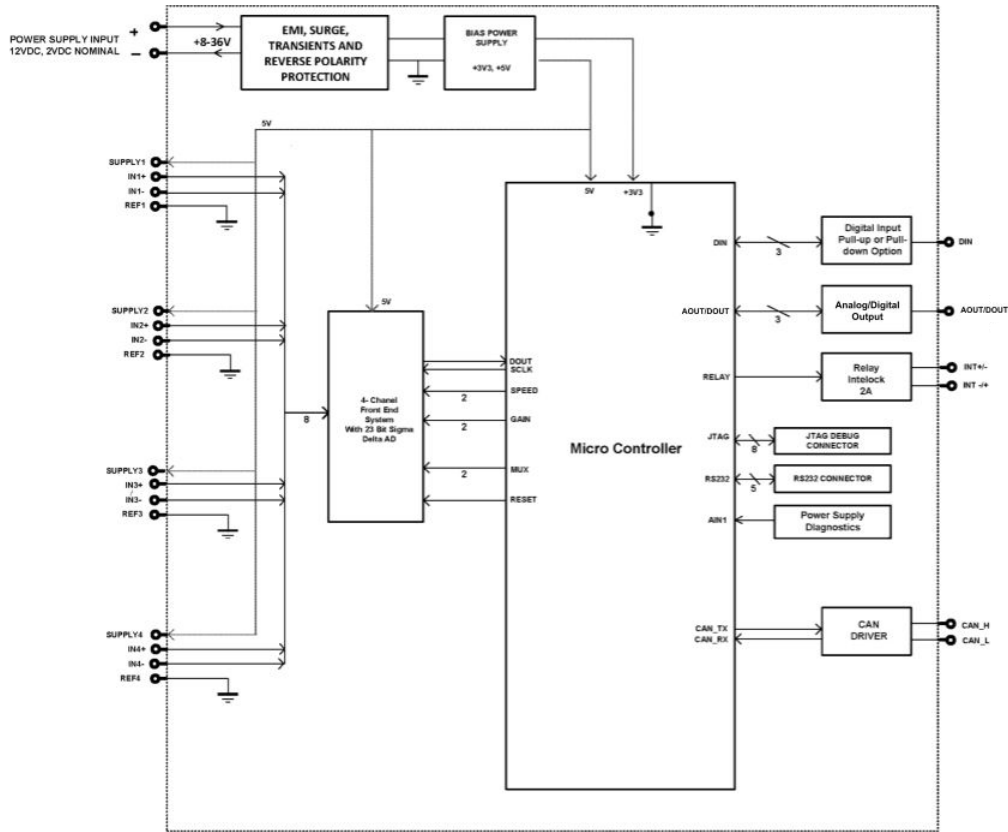

Dimensions:

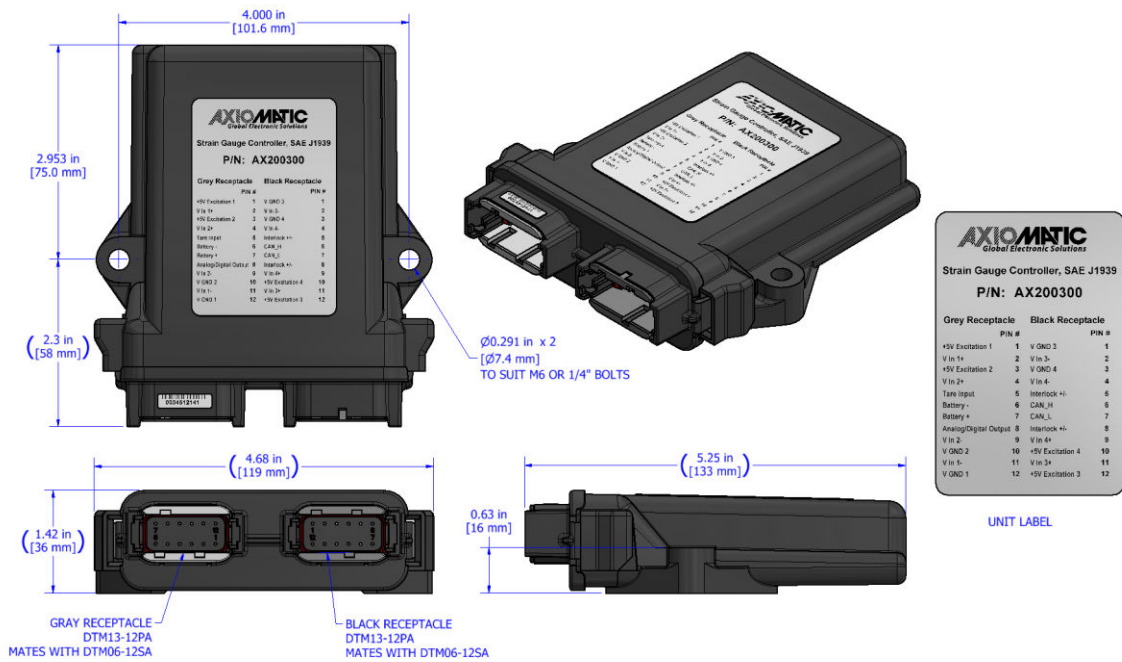

Technical Specifications:

Specifications are indicative and subject to change. Actual performance will vary depending on the application and operating conditions. Users should satisfy themselves that the product is suitable for use in the intended application. All our products carry a limited warranty against defects in material and workmanship. Please refer to our Warranty, Application Approvals/Limitations and Return Materials Process as described on <https://www.axiomatic.com/service/>.

Power Input Specifications

Power Supply Input - Nominal	12 or 24Vdc nominal operating voltage 8...36 Vdc power supply range for voltage transients
Surge Protection	Provided
Reverse Polarity Protection	Provided

Input Specifications

Strain Gauge Inputs	4 Channels Accepts 4-wire Strain Gauge inputs Input range selectable from +/- 19.5 mV to +/- 2.5 Vdc. All input channels have excitation and ground connections provided. All inputs send a message to the CAN bus.
Measurement rate	The measurement rate is configurable from 60 to 40,000 scans per second for all 4 channels. The update rate is 80 ms for all 4 channels.
Common-mode	Common-mode rejection is > 100 db@ 1V p-p, simultaneous 50/60 Hz. Common mode input range is +/- 3.5V maximum.
Resolution	18.2-Bit noise-free minimum
Drift	Overall drift with temperature is 50 ppm/°C of span (maximum).
Input Accuracy	+/- 0.5% throughout the entire range of the input
Excitation	4 +5V excitation connections
Other Input	1 Digital Input Active High to 5V or Active Low to GND Configurable Pull Up or Pull Down Resistor Amplitude: up to +Vps
Grounds	4 GND connections

Output

Analog/Digital Output	1 Analog/Digital Output Analog Output has selectable range of 0 to 10 V and 0 to 24 mA Digital Output On/Off Fully protected high side digital switch with low current readings 2A Overcurrent, overvoltage and undervoltage protection is provided.
Relay Output	An interlock relay with 2 contact pins is provided. 2A (nominal)

General Specifications

Microcontroller	STM32F407VGT7
Quiescent Current Draw	60.9 mA @ 12V 31.5 mA @ 24V
Communications	1 CAN port (SAE J1939) Baud rate: 250, 500, 667 kbit/s, 1 Mbit/s. Automatic baud rate detection.
Wire Break Detection	Included
Control Logic	Standard embedded control logic is provided. Refer to the User Manual for details. Application-specific control logic is available on request.

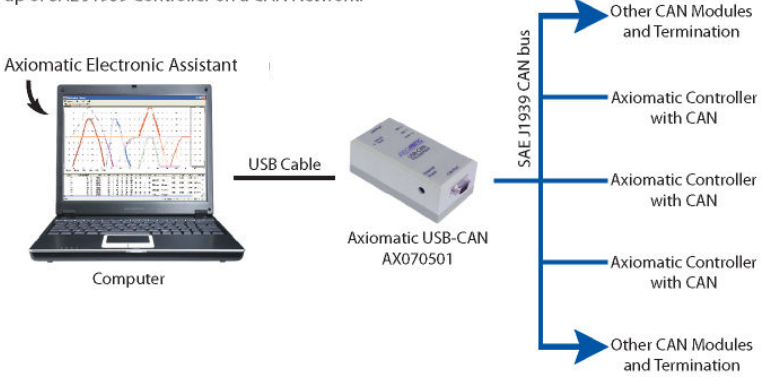
<p>User Interface</p>	<p>The Axiomatic Electronic Assistant, P/Ns: AX070502, or AX070506K User configuration and diagnostics are provided with the Axiomatic Electronic Assistant. The Axiomatic Service Tool is a <i>Windows</i>-based graphical user interface that allows easy configuration of the controller setpoints.</p> <p>Set up of SAE J1939 Controller on a CAN Network:</p> 																																																								
<p>SAE J1939 Compliance</p>	<p>The ECU is compliant with the following SAE J1939 standards.</p> <ul style="list-style-type: none"> • SAE J1939-21, Dec 2006, Data Link Layer • SAE J1939-71, Sep 2013, Application Layer • SAE J1939-73, Feb 2010, Application Layer – Diagnostic • SAE J1939-81, March 2017, Network Management 																																																								
<p>Electrical Connections</p>	<p>24-pin receptacle (TE Deutsch DTM series equivalent: DTM13-12PA-12PB-R008) Mating plug: Equivalent to the TE Deutsch DTM06-12SA and DTM06-12SB, with 2 wedgelocks (WM12S) and 24 contacts (0462-201-20141). 20 AWG wire is recommended for use with contacts 0462-201-20141.</p> <table border="1" data-bbox="670 993 1307 1402"> <thead> <tr> <th colspan="2">Grey Connector</th> <th colspan="2">Black Connector</th> </tr> <tr> <th>Pin #</th> <th>Function</th> <th>Pin #</th> <th>Function</th> </tr> </thead> <tbody> <tr> <td>1</td> <td>+5V Excitation 1</td> <td>1</td> <td>GND 3</td> </tr> <tr> <td>2</td> <td>V IN 1+</td> <td>2</td> <td>V IN 3-</td> </tr> <tr> <td>3</td> <td>+5V Excitation 2</td> <td>3</td> <td>GND 4</td> </tr> <tr> <td>4</td> <td>V IN 2+</td> <td>4</td> <td>V IN 4-</td> </tr> <tr> <td>5</td> <td>Tare Input</td> <td>5</td> <td>Interlock +/-</td> </tr> <tr> <td>6</td> <td>BATT-</td> <td>6</td> <td>CAN_H</td> </tr> <tr> <td>7</td> <td>BATT+</td> <td>7</td> <td>CAN_L</td> </tr> <tr> <td>8</td> <td>Digital Output</td> <td>8</td> <td>Interlock +/-</td> </tr> <tr> <td>9</td> <td>V IN 2 -</td> <td>9</td> <td>V IN 4+</td> </tr> <tr> <td>10</td> <td>GND 2</td> <td>10</td> <td>+5V Excitation 4</td> </tr> <tr> <td>11</td> <td>V IN 1 -</td> <td>11</td> <td>V IN 3+</td> </tr> <tr> <td>12</td> <td>GND 1</td> <td>12</td> <td>+5V Excitation 3</td> </tr> </tbody> </table>	Grey Connector		Black Connector		Pin #	Function	Pin #	Function	1	+5V Excitation 1	1	GND 3	2	V IN 1+	2	V IN 3-	3	+5V Excitation 2	3	GND 4	4	V IN 2+	4	V IN 4-	5	Tare Input	5	Interlock +/-	6	BATT-	6	CAN_H	7	BATT+	7	CAN_L	8	Digital Output	8	Interlock +/-	9	V IN 2 -	9	V IN 4+	10	GND 2	10	+5V Excitation 4	11	V IN 1 -	11	V IN 3+	12	GND 1	12	+5V Excitation 3
Grey Connector		Black Connector																																																							
Pin #	Function	Pin #	Function																																																						
1	+5V Excitation 1	1	GND 3																																																						
2	V IN 1+	2	V IN 3-																																																						
3	+5V Excitation 2	3	GND 4																																																						
4	V IN 2+	4	V IN 4-																																																						
5	Tare Input	5	Interlock +/-																																																						
6	BATT-	6	CAN_H																																																						
7	BATT+	7	CAN_L																																																						
8	Digital Output	8	Interlock +/-																																																						
9	V IN 2 -	9	V IN 4+																																																						
10	GND 2	10	+5V Excitation 4																																																						
11	V IN 1 -	11	V IN 3+																																																						
12	GND 1	12	+5V Excitation 3																																																						

Enclosure and Dimensions	High Temperature Nylon Enclosure - (TE Deutsch PCB P/N: EEC-325X4B) 4.68 x 5.25 x 1.42 inches 119 x 133 x 36 mm (W x L x H excluding mating plugs) Flammability Rating: UL 94V-0
Operating Temperature	-40°C to 85°C (-40°F to 185°F)
Storage Temperature	-50°C to 125°C (-58°F to 257°F)
Weight	0.50 lb. (0.23 kg)
Protection	IP67
Vibration	MIL-STD-202G, Test 204D and 214A (Sine and Random) 10 g peak (Sine) 7.86 Grms peak (Random)
Shock	MIL-STD-202G, Test 213B 50g
Mounting	Mounting holes sized for ¼ inch or M6 bolts. The bolt length will be determined by the end-user's mounting plate thickness. The mounting flange of the controller is 0.63 inches (16 mm) thick. All field wiring should be suitable for the operating temperature range. Install the unit with appropriate space available for servicing and for adequate wire harness access (6 inches or 15 cm) and strain relief (12 inches or 30 cm).

Key Arrangement B (black)

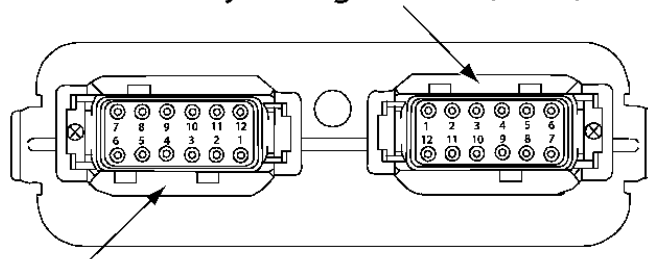

Key Arrangement A (grey)

FRONT VIEW 24 PIN RECEPTACLE

Notes: CANopen® is a registered community trademark of CAN in Automation e.V

Form: TDAX200300-07/27/23