

**Technical Datasheet #TDAX184000**  
**12 RTD Scanner**

**12 RTD Channels**  
**4 Universal Signal Inputs**  
**CAN, SAE J1939**  
*with the Axiomatic Electronic Assistant*  
**P/N: AX184000**

**Description:** The RTD Scanner monitors 12 3-wire or 2-wire RTD inputs from a diesel engine and the temperature information is provided to the engine control system over a SAE J1939 CAN bus. Each channel operates independently. Temperature information can include exhaust temperature, winding temperature, and fluid temperature monitoring. All channels of temperature data are automatically sent over the CAN bus when power is applied with no additional programming or configuration required. Integral diagnostics determine RTD integrity. RTD inputs are isolated from the CAN communication and power supply.



Four (4) universal signal inputs are user selectable as voltage (0-5V, 0-10V), current (4-20 mA, 0-20mA), PWM (0-10kHz), counter or digital (active high, active low or latched) input types.

During set-up, using a USB-CAN converter and a PC, the operator can configure the controller via the Axiomatic Electronic Assistant to suit a wide variety of applications.

The RTD Scanner features rugged packaging and watertight connectors for an IP67 rating. The RTD Scanner's connectors are TE Deutsch equivalents. The RTD Scanner is designed to meet the environmental, EMC and vibration requirements of generator set applications.

**Applications:**

- Stationary, portable power generator sets
- Genset control systems

**Ordering Part Numbers:**

12 RTD Scanner Module, SAE J1939 250 kbps P/N: **AX184000**

12 RTD Scanner Module, SAE J1939 500 kbps P/N: **AX184000-01**

12 RTD Scanner Module, SAE J1939 1 Mbps P/N: **AX184000-02**

Axiomatic Electronic Assistant Configuration KIT, P/Ns: **AX070502, AX070505K, or AX070506K**

Mating Plug Kit P/N: **AX070200**

These items are also available from a local TE Deutsch distributor. See the technical specifications below for more details.

## Block Diagram

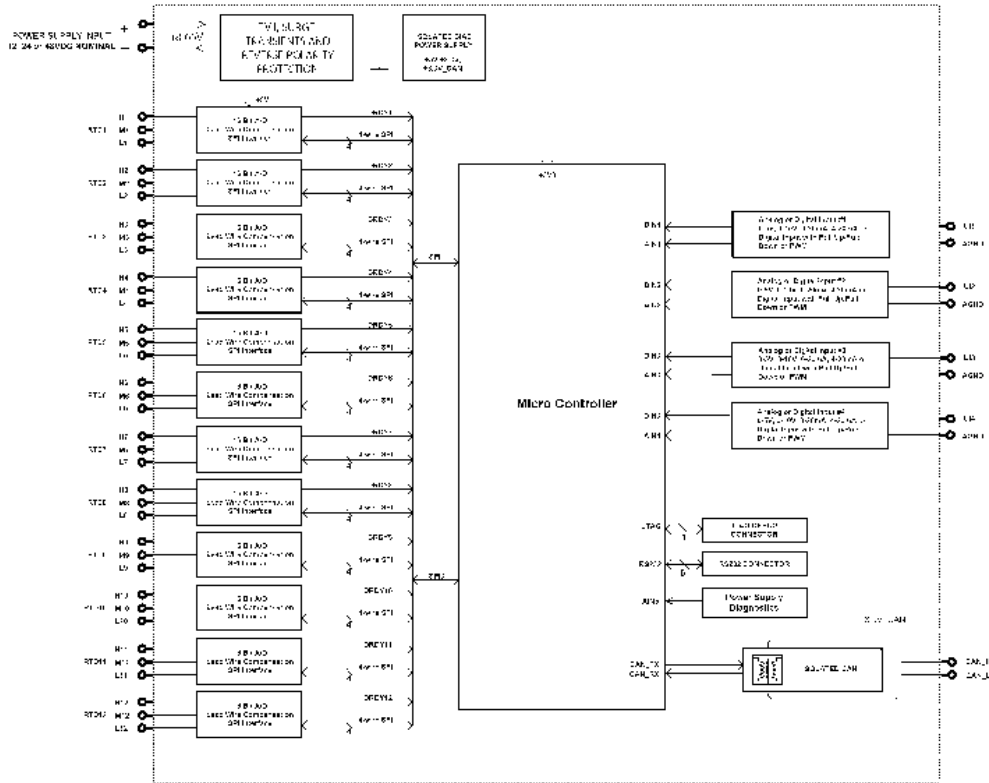

## Technical Specifications:

Specifications are indicative and subject to change. Actual performance will vary depending on the application and operating conditions. Users should satisfy themselves that the product is suitable for use in the intended application. All our products carry a limited warranty against defects in material and workmanship. Please refer to our Warranty, Application Approvals/Limitations and Return Materials Process as described on <https://www.axiomatic.com/service/>.

## Power and Protections

Power Supply Input	12V or 24VDC nominal (8...65 VDC power supply range) 50 or 60 Hz is user selectable.
Supply Current	90 mA at 12 Vdc Typical 45 mA at 24 Vdc Typical Inrush does not exceed 500 mA.
Protection	Reverse polarity protection is provided. Power supply input section protects against transients, surges (up to 175V) and short circuits and is isolated from RTD inputs

## RTD Inputs

RTD Types	Up to 12 channels, independently configurable for 2 or 3 wire RTDs. Each channel operates independently.
RTD Inputs	Each channel independently supports specific sensors IEC 0.00385, JIS 0.003916, US 0.003902, Legacy 0.003920, SAMA 0.003923. A user defined coefficient would enable custom Callendar-Van Dusen constants to be set for sensors not listed above. The device accepts inputs within the following range of 20 - 400 Ohms. RTD lead resistance range is 0 – 10 Ohms. Accuracy: +/- 1°C with offset calibration performed at R = 100 Ohms (typical at ambient temperature) Resolution: 0.001°C Isolation voltage is 500V.

Shield	To connect a Shield, use the grounding stud provided on the base plate.
Scan Rate	50ms per channel, total sweep time maximum 50 ms 20 samples per second for all 12 channels
Common Mode Readings	Input range +/- 0-2Vdc maximum Rejection is 115 db at 5Vp-p (50-60Hz)
Thermal Drift	40 ppm/°C of span (maximum)
Isolation	Digital isolation is 500VDC from input to ground. Three-way isolation is provided for the CAN line, inputs and power supply.
SPNs and PGNs	The SPN drop list includes all temperature SPNs from the J1939-71 standard published up to January of 2009. If an SPN is not supported by the drop list, the user can select a zero SPN, which then allows them to define the SPN and PGN per the application requirements.  One byte parameters have a resolution of 1 °C / bit and a range of -40 °C to 210 °C. Two byte parameters have resolution of 0.03125 °C / bit and a range of -273 °C to 1735 °C (per SAE J1939).  The Parameter Group Number (PGN) that will be used to send a temperature to the J1939 network will be entirely dependent on the Suspect Parameter Number (SPN) that was selected for that channel. In all cases, the PGN is a PDU2 type. Each PGN has a predefined priority and repetition rate associate with it.
Averaging	The average temperature of all the active channels can be broadcasted to the network using the default "Engine Average Information" PGN, or on a Proprietary B message.
Protection	Open circuit detection Frozen data detection Over or under temperature detection High temperature shutdown detection

### Signal Inputs

Universal Inputs (4)	Four universal inputs are user selectable as: voltage; current; PWM; or digital types. 12-bit Analog to Digital resolution. Protected against shorts to GND.  Voltage Types: 0-5Vdc or 0-10Vdc 1mV resolution, accuracy +/- 1% error  Current Types: 0-20 mA or 4-20 mA Current sense resistor 249Ω 1uA resolution, accuracy +/- 1% error  Frequency: 0.5 to 50Hz or 10 Hz to 1 kHz or 100 Hz to 10 kHz Frequency Input: 0.01% resolution, accuracy +/- 1% error  PWM Signal Frequency: Low (0-1000 Hz) or High (100 Hz to 10,000 Hz) PWM Duty Cycle: 0 to 100% PWM Input: 0.01% resolution, accuracy +/- 1% error  Counter Counter Input: 0.01% resolution, accuracy +/- 1% error  Digital Input: 1MΩ Impedance or Active High with 10K Pullup or Active Low with 10K Pulldown resistor to GND or Latched Amplitude: up to +Vsupply
Analog Grounds	Four (4) analog ground connections are provided.

### Communications

CAN	1 CAN 2.0B port, protocol SAE J1939 Model AX184000: 250 kbps Baud Rate Model AX184000-01: 500 kbps Baud Rate Model AX184000-02: 1 Mbps Baud Rate Digital isolation is provided for the CAN line.
Network Termination	According to the CAN standard, it is necessary to terminate the network with external termination resistors. The resistors are 120 Ohm, 0.25W minimum, metal film or similar type. They should be placed between CAN_H and CAN_L terminals at both ends of the network.

## General Specifications

Microprocessor	STM32F205VG 12-bit, 1 Mbyte Flash Memory
Control Logic	User programmable functionality with the Axiomatic Electronic Assistant: <ul style="list-style-type: none"> <li>• Node address is auto configurable as per J1939-81 and/or via customer configuration.</li> <li>• Monitored parameters and diagnostics are user selectable from a drop down list in the Axiomatic EA. Monitored parameters and diagnostics are read-only over the network</li> <li>• All parameter locations have default values that do not conflict. Units are pre-configured with default values at the factory. Refer to the user manual.</li> <li>• Parameter values and diagnostic error codes are retained when the modules are de-energized.</li> <li>• Easily selectable SPNs from a drop down list of the temperature SPNs supported by SAE J1939.</li> <li>• User defined SPN and PGN's configurable with the Axiomatic Electronic Assistant to suit the application.</li> <li>• Configurable ECU Instance in the NAME to allow for multiple ECU's on the same network</li> <li>• The bit-rate is 250 kbit/s. Other bit-rates (125 kbit/s, 500 kbit/s or 1 Mbit/s) can be factory programmed on request. Contact Axiomatic for p/n.</li> <li>• Module is fully functional during configuration and communications.</li> </ul>
SAE J1939 Profile	For J1939 compliance (SAE, Recommended Practice for a Serial Control and Communications Vehicle Network, October 2007) all modules comply with the applicable portions of the following: <p>SAE J1939-21, December 2006, Data Link Layer  SAE J1939-71, January 2009, Vehicle Application Layer  SAE J1939-73, September 2006, Application Layer – Diagnostics  SAE J1939-81, May 2003, Network Management</p> <i>Customer specific proprietary extensions can also be included in the SAE J1939 profile on request.</i>
Diagnostics	Configurable Diagnostic Messaging parameters Active Diagnostic Trouble Code (DM1) containing Diagnostic Trouble Code (DTC). Refer to the User Manual for details.  Diagnostic Log is maintained in non-volatile memory.  Each RTD channel can be configured to send diagnostic messages to the network if the temperature goes out of range.
User Interface	The Axiomatic Electronic Assistant KIT, P/Ns: AX070502, AX070505K, or AX070506K. Updates for the Axiomatic EA are found on <a href="http://www.axiomatic.com">www.axiomatic.com</a> under the log-in tab.
UL and cUL Compliance	Pending
CE Compliance	2004/108/EC (EMC Directive) pending 2011/65/EU (RoHS Directive)
Vibration	MIL-STD-202G, Test 204D and 214A (Sine and Random) 10 g peak (Sine); 7.86 Grms peak (Random)
Shock	MIL-STD-202G, Test 213B, 50 g
Operating Temperature Range	-40 to 85 °C (-40 to 185 °F)
Storage Temperature Range	-50 to 120 °C (-58 to 248 °F)
Humidity	Protected against 95% humidity non-condensing, 30 °C to 60 °C
Protection	IP67
Weight	2.1 lb. (0.96 kg)
Enclosure	Rugged aluminum housing, stainless steel end plates, neoprene gaskets 145.30 x 149.00 x 73.00 mm (5.72 x 5.86 x 2.87") L x W x H Connectors (equivalent TE Deutsch P/N: 1 8-pin DT13-08PA, 1 40-pin DRC13-40PB) Can be mounted directly on the power generator set or remotely Suitable for moist, high shock, vibrating and non-hazardous environments

## Dimensional Drawing

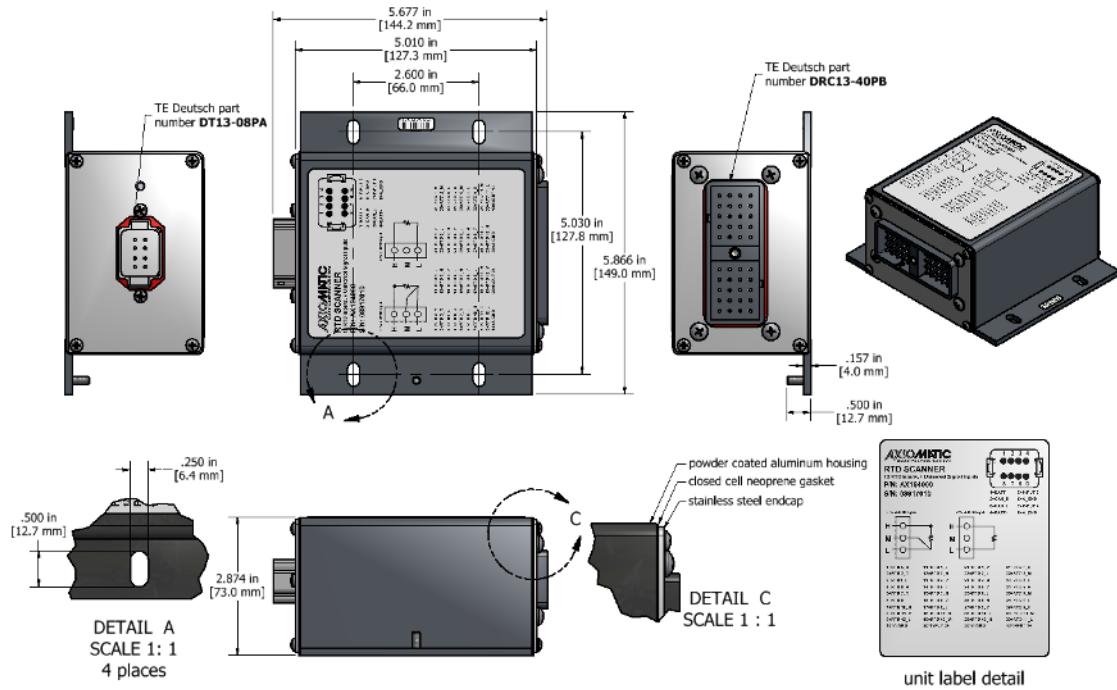

Mating Plug Kit	<p>Mating Plug Kit P/N: <b>AX070200</b></p> <p>This kit includes the following items. These items are also available from a local TE Deutsch distributor.</p> <p><i>NB. The sealing plugs are only needed in cases where not all of the 40 pins are used.</i></p> <p>A crimping tool from TE Deutsch is required to connect wiring to the sockets, P/N: HDT 48-00 or equivalent (not supplied).</p>											
	<table border="1"> <thead> <tr> <th>TE Deutsch P/N:</th> <th>Description:</th> </tr> </thead> <tbody> <tr> <td>0462-201-16141</td> <td>48 16AWG SOCKETS SOLID 16-20AWG WIRE 6mm</td> </tr> <tr> <td>114017</td> <td>24 SEALING PLUGS SIZE 12-16 CAVITIES 12-18 AWG</td> </tr> <tr> <td>DRC16-40S</td> <td>40-PIN PLUG, No Key</td> </tr> <tr> <td>DT06-08SA</td> <td>DT SERIES PLUG 8 CONTACT</td> </tr> <tr> <td>W8S</td> <td>WEDGELOCK FOR DT 8 PIN PLUG</td> </tr> </tbody> </table>	TE Deutsch P/N:	Description:	0462-201-16141	48 16AWG SOCKETS SOLID 16-20AWG WIRE 6mm	114017	24 SEALING PLUGS SIZE 12-16 CAVITIES 12-18 AWG	DRC16-40S	40-PIN PLUG, No Key	DT06-08SA	DT SERIES PLUG 8 CONTACT	W8S
TE Deutsch P/N:	Description:											
0462-201-16141	48 16AWG SOCKETS SOLID 16-20AWG WIRE 6mm											
114017	24 SEALING PLUGS SIZE 12-16 CAVITIES 12-18 AWG											
DRC16-40S	40-PIN PLUG, No Key											
DT06-08SA	DT SERIES PLUG 8 CONTACT											
W8S	WEDGELOCK FOR DT 8 PIN PLUG											

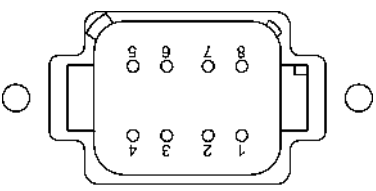
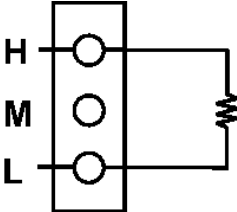
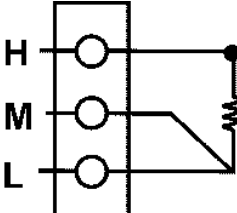
<p>Electrical Pin Out – Power, CAN, Universal Signal Inputs 3 and 4</p>	<p>1 8-pin connector (equivalent TE Deutsch P/N: DT13-08PA)</p>  <table border="1" data-bbox="625 451 1039 682"> <thead> <tr> <th>PIN#</th> <th>Description</th> </tr> </thead> <tbody> <tr> <td>1</td> <td>BATT +</td> </tr> <tr> <td>2</td> <td>CAN H</td> </tr> <tr> <td>3</td> <td>CAN L</td> </tr> <tr> <td>4</td> <td>BATT -</td> </tr> <tr> <td>5</td> <td>Universal Input 3 +</td> </tr> <tr> <td>6</td> <td>Analog GND</td> </tr> <tr> <td>7</td> <td>Universal Input 4+</td> </tr> <tr> <td>8</td> <td>Analog GND</td> </tr> </tbody> </table>	PIN#	Description	1	BATT +	2	CAN H	3	CAN L	4	BATT -	5	Universal Input 3 +	6	Analog GND	7	Universal Input 4+	8	Analog GND
PIN#	Description																		
1	BATT +																		
2	CAN H																		
3	CAN L																		
4	BATT -																		
5	Universal Input 3 +																		
6	Analog GND																		
7	Universal Input 4+																		
8	Analog GND																		
<p>RTD Input Wiring</p>	<p>2-wire RTD Input:</p>  <p>3-wire RTD Input:</p> 																		

Electrical Pin Out – 12 RTD Inputs,  
Universal Signal Inputs 1 and 2

1 40-pin connector (equivalent TE Deutsch P/N: DRC13-40PB)

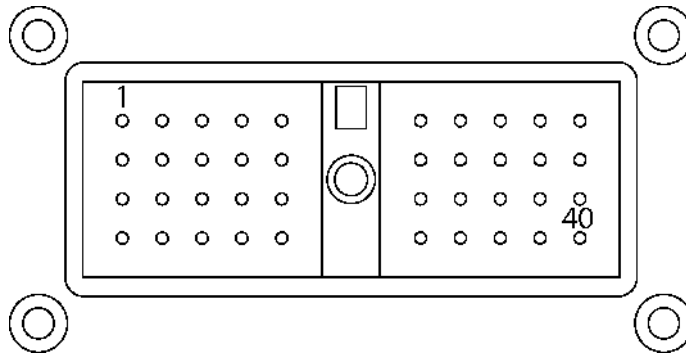

PIN#	Description
1	RTD 2 High
2	RTD 3 Medium
3	RTD 4 Low
4	RTD 6 High
5	RTD 7 Medium
6	RTD 8 Low
7	RTD 10 High
8	RTD 11 Medium
9	RTD 12 Low
10	Analog GND
11	RTD 1 Low
12	RTD 3 High
13	RTD 4 Medium
14	RTD 5 Low
15	RTD 7 High
16	RTD 8 Medium
17	RTD 9 Low
18	RTD 11 High
19	RTD 12 Medium
20	Universal Input 2
21	RTD 1 Medium
22	RTD 2 Low
23	RTD 4 High
24	RTD 5 Medium
25	RTD 6 Low
26	RTD 8 High
27	RTD 9 Medium
28	RTD 10 Low
29	RTD 12 High
30	Analog GND
31	RTD 1 High
32	RTD 2 Medium
33	RTD 3 Low
34	RTD 5 High
35	RTD 6 Medium
36	RTD 7 Low
37	RTD 9 High
38	RTD 10 Medium
39	RTD 11 Low
40	Universal Input 1

Form: TDAX184000-06/20/23