

Features

- 12V, 24Vdc input power (nominal) for connection to a battery
- 1 CAN port (2.0A and B protocol)
- 1 Ethernet port (10/100 Mbps) for multiple Ethernet devices on a machine (Ethernet IEEE 802.3, IP, ICMP, ARP, UDP, TCP, HTTP, Proprietary protocols)
- Supports CAN filtering
- Power, Link and Speed LED indicators
- 1 power output (Vps) to power an external device over the Ethernet cable
- Surge, Reverse polarity, input overvoltage, input undervoltage, and output overcurrent protection
- IP66
- Compact, 2 M12 connectors
- Suitable for high vibration and shock environments
- CE marking
- Available as a kit with cables, P/N: AX140900K



Applications

- Off-highway equipment, mining equipment
- Industrial control panels

Ordering Part Numbers

Ethernet/CAN Converter - P/N: **AX140900**

Accessories:

- Software Support Package - P/N: **AX140910**
- Ethernet to CAN Converter Discovery Protocol Document
- Ethernet to CAN Converter Communication Protocol Document
- Ethernet to CAN Converter Health Status Document
- **AX070531** - Ethernet and Power Cable - 1.7m (5.5 ft.), 8-pin M12 A-coded, Unterminated Leads, Ethernet Jack
- **AX070532** - CAN Cable - 1.5 m (5 ft.), 5-pin M12 A-coded, Unterminated Leads

You can also order the items as a service tool kit. The **AX140900K** KIT comprises the following items.

- AX140900 - Ethernet-CAN Converter
- AX070531 - Ethernet and Power Cable - 1.7m (5.5 ft.), 8-pin M12 A-coded, Unterminated Leads, Ethernet Jack
- AX070532 - CAN Cable - 1.5 m (5 ft.), 5-pin M12 A-coded, Unterminated Leads

Description

The Ethernet/CAN Converter operates as a simple data converter capable of handling communication between Ethernet IEEE 802.3, IP ICMP, ARP, UDP, TCP, HTTP or proprietary protocol devices and a machine's CAN bus. Communication can occur in either direction, Ethernet to CAN or CAN to Ethernet. It can be utilized for CAN bus monitoring, two-way remote CAN bus monitoring and synchronization as well as CAN bus extension over Ethernet applications. CAN frames are converted into a simple data encoding and sent over Ethernet to the Ethernet device. Likewise, data received from the Ethernet device is decoded into CAN frames and sent via CAN bus to the connected CAN device. CAN filtering is supported. The converter can be utilized to optimize space and eliminate the need for more complex devices. The Ethernet port can communicate up to 100 Mbps and has LED indicators showing the status and speed. The CAN port has overcurrent protection that triggers at 1A. It supports high speed CAN with a baud rate of up to 1 Mbps. All standard and extended CAN frames, including data and remote frames are supported. It can interface with SAE J1939 or CANopen®. The power can be delivered to the CAN port over the Ethernet connection. Protection is provided. The converter is designed for the harsh environments of off-highway equipment or industrial equipment.

The Ethernet to CAN Converter firmware contains two independent parts: the *Communication Device* and the *Web Server*, see Figure 1:

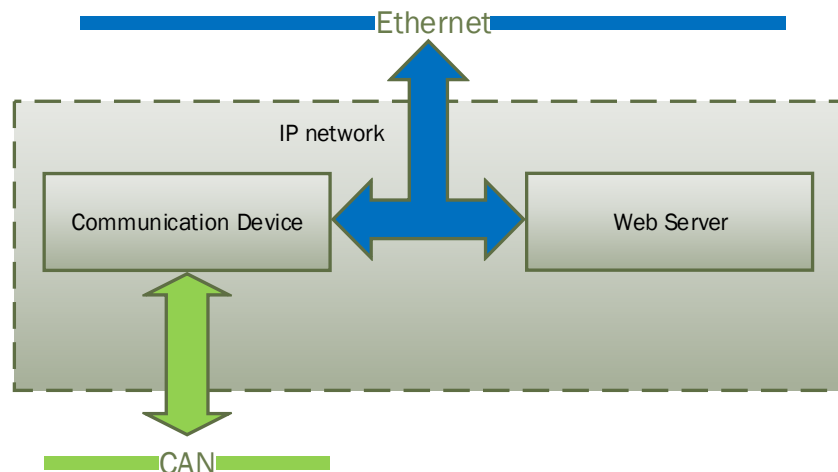

Figure 1. Converter Firmware Architecture

The *Communication Device* is responsible for the protocol conversion between CAN and Ethernet networks and the *Web Server* provides the converter user interface.

There are two major approaches in using the Ethernet to CAN converter. One is to use the converter on its own as a CAN extender or a baud rate converter.

For example, a pair of coupled converters can synchronize two CAN networks. This example can be extended to several CAN networks running at different baud rate in various remote locations, connected using the Ethernet to CAN converters.

The second approach is to use the converter together with other IP devices that can directly communicate with the converter over the IP network. This approach requires writing a custom software for interfacing with the converter. Since the converter uses a proprietary communication protocol, Axiomatic provides the CAN-ENET Software Support Package (SSP), P/N AX140910, for interfacing with the converter.

Functional Block Diagram

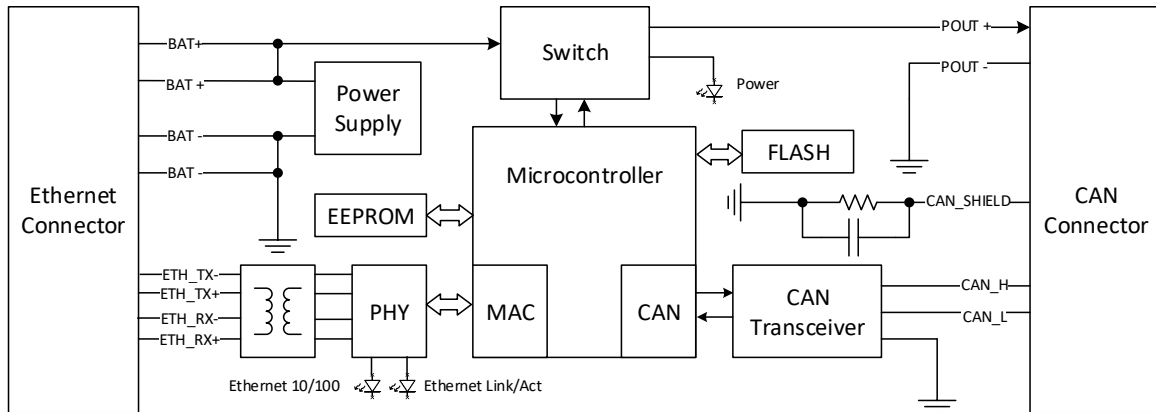

Technical Specifications

Specifications are indicative and subject to change. Actual performance will vary depending on the application and operating conditions. Users should satisfy themselves that the product is suitable for use in the intended application. All our products carry a limited warranty against defects in material and workmanship. Please refer to our Warranty, Application Approvals/Limitations and Return Materials Process as described on <https://www.axiomatic.com/service/>.

Input Specifications

Power Supply Input	12V, 24Vdc nominal (9 to 36VDC power supply range)
Protections	Surge and reverse polarity protection are provided. Input overvoltage (37V), input undervoltage (6V) and output overcurrent protection are provided.
Power Consumption	2 Watts @ 12Vdc maximum
Power LED	GREEN= Power ON RED = Fault condition GREEN/RED = Power OFF

Output Specifications

Power	Pass-through power from the power supply input Power output is available from Port 2. 9...36Vdc (Vps) 0.7A maximum pass-through current Voltage Drop 1V maximum Overcurrent protection Short to Battery and Short to Ground protection
-------	--------------------------------------------------------------------------------------------------------------------------------------------------------------------------------------------------------------------------------------------------------------

Ethernet Port

Port Type	1 port 10/100 Mbit Ethernet compliant 10BASE-T, 100BASE-Tx (auto-configuration and full-duplex supported)
MDIX	Auto-MDIX
LEDs	2 GREEN for Ethernet LINK/ACT: ON means connection (LINK) Flashing means activity (ACT) OFF means Ethernet connection is down Transmission Speed: 100 Mbit/s = ON 10 Mbit/s = OFF
Protocols	Ethernet IEEE 802.3, IP, ICMP, ARP, UDP, TCP, HTTP, Proprietary
Server Mode	Up to 10 bi-directional simultaneous connections
Client Mode	1 remote bi-directional connection
Web Server	Provided
Internal Diagnostics	Health status is transmitted in heartbeat messages. It is also available from the web server.

CAN Port

Port Type	1 port High speed, ISO 11898-2 compatible, 1 Mbit/s Shield is provided.
Protocol	CAN 2.0A and B protocol (Data frames and remote frames with standard and extended ID's are supported.)
Baud rate (kBit/s)	1000, 666.6, 500, 250, 125, 100, 83.3(3), 50, 20, 10 baud rates (user programmable)

General Specifications

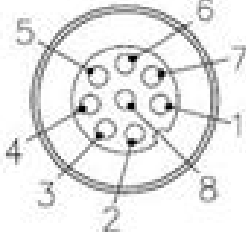
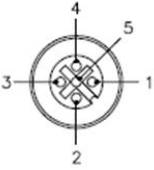
Documentation	User Manual, UMAX140900 Ethernet to CAN Converter Discovery Protocol Software Support Package, AX140910																														
User Interface	Web server based interface (custom) Refer to Figure 2.0. Configurable parameters include: of IP address, baud rate, server port, Ethernet Port type (UDP or TCP), Local IP address, Local Port, Remote IP address, Remote Port, and Power output to CAN port ON/OFF. Diagnostic information includes: CAN Receive errors, CAN Transmit errors, CAN Bus Off errors, CAN Frames Received, CAN Frames sent, Ethernet Messages received, Ethernet Messages sent, and Device Health status (heartbeat).																														
Compliance	CE, RCM and UKCA marking																														
EMC Compliance	DIN EN 13309:2010 as well as ISO13766-1:2018 EN61000-6-4; 2005 Emission Standard for Industrial Environments EN61000-6-2: 2007 Generic Standards – Immunity for Industrial Environments EN61000-4-2: ESD, Level 4 (15 kV air/8 kV contact) at Criteria B EN61000-4-4: EFT/burst Immunity, Test Level 1 (500V power/250V signal lines) at Performance Criteria B EN61000-4-5: Surge Immunity, Test Level 1 (500V) at Performance Criteria B.																														
Enclosure and Dimensions	See dimensional drawing, Figure 3.0. Nylon 6/6, 30% glass fill UL 94V-0 Ultrasonically welded																														
Weight	0.15 lb. (0.068 kg) AX070531 : 0.39 lb. (0.178 kg) AX070533 : 0.69 lb. (0.313 kg)																														
Operating Conditions	-40 to 70°C (-40 to 158°F)																														
Storage Temperature	-40 to 85°C (-40 to 185°F)																														
Protection	IP66 (IEC 60529)																														
Vibration	Random Vibration: 6.86 Grms peak, Z-axis tracked vehicle profile (5 hr/axis in all 3 axes) Sinusoidal Component: 8.9 G Sine sweep, 2.5 hr/axis in all 3 axes																														
Shock	50 g, 5 impacts per test, 6-20 ms impact duration																														
Electrical Connections	<p>Ethernet Port: Power In, Ethernet 1 Phoenix Contact M12 8-pin connector (A-coded), P/N: 1441817 (Connector 1)</p> <table border="1"> <thead> <tr> <th>PIN#</th> <th>Description</th> </tr> </thead> <tbody> <tr> <td>1</td> <td>Power IN</td> </tr> <tr> <td>2</td> <td>Power GND</td> </tr> <tr> <td>3</td> <td>Power GND</td> </tr> <tr> <td>4</td> <td>Ethernet TX-</td> </tr> <tr> <td>5</td> <td>Ethernet RX+</td> </tr> <tr> <td>6</td> <td>Ethernet TX+</td> </tr> <tr> <td>7</td> <td>Power IN</td> </tr> <tr> <td>8</td> <td>Ethernet RX-</td> </tr> </tbody> </table>  <p>CAN Port: Power Out, CAN 1 Phoenix Contact M12 5-pin connector (A-coded), P/N: 1441778 (Connector 2)</p> <table border="1"> <thead> <tr> <th>PIN#</th> <th>Description</th> </tr> </thead> <tbody> <tr> <td>1</td> <td>CAN_SHIELD</td> </tr> <tr> <td>2</td> <td>Power Out (+ Voltage)</td> </tr> <tr> <td>3</td> <td>Power GND (- Voltage)</td> </tr> <tr> <td>4</td> <td>CAN_H</td> </tr> <tr> <td>5</td> <td>CAN_L</td> </tr> </tbody> </table> 	PIN#	Description	1	Power IN	2	Power GND	3	Power GND	4	Ethernet TX-	5	Ethernet RX+	6	Ethernet TX+	7	Power IN	8	Ethernet RX-	PIN#	Description	1	CAN_SHIELD	2	Power Out (+ Voltage)	3	Power GND (- Voltage)	4	CAN_H	5	CAN_L
PIN#	Description																														
1	Power IN																														
2	Power GND																														
3	Power GND																														
4	Ethernet TX-																														
5	Ethernet RX+																														
6	Ethernet TX+																														
7	Power IN																														
8	Ethernet RX-																														
PIN#	Description																														
1	CAN_SHIELD																														
2	Power Out (+ Voltage)																														
3	Power GND (- Voltage)																														
4	CAN_H																														
5	CAN_L																														
Mating Connectors	Mating connectors should meet the following standard for M12 Connectors, IEC 61076-2-101:2012. They should be A-coded.																														

AXOMATIC Global Electronic Solutions Ethernet to CAN Converter

- [Home](#)
- [Main Settings](#)
- [CAN ID Range Filters](#)
- [CAN ID Mask Filters](#)
- [Diagnostics](#)
- [Firmware](#)

DEVICE INFORMATION

Part Number: AX140900
 Serial Number: 0014016001
 Firmware Version: V4.00

ETHERNET

MAC Address: B4:37:D1:A0:00:0A

Server

Device IP Address: 192.168.0.34
 Device Port: 4000
 Device Port Type: UDP
 Web Server Port: 80
 Device Subnet Mask: 255.255.255.0
 Device Default Gateway: 192.168.0.1

Client

Auto Connect to Remote: No
 Remote IP Address: 192.168.0.35
 Remote Port: 4000

CAN

Switched Power Out: Off
 Baud Rate: 250 kbit/s
 ID Range Filters: Off
 ID Mask Filters: Off
 Loopback Messages: No

Figure 2.0 – Web-based User Interface – Converter Homepage

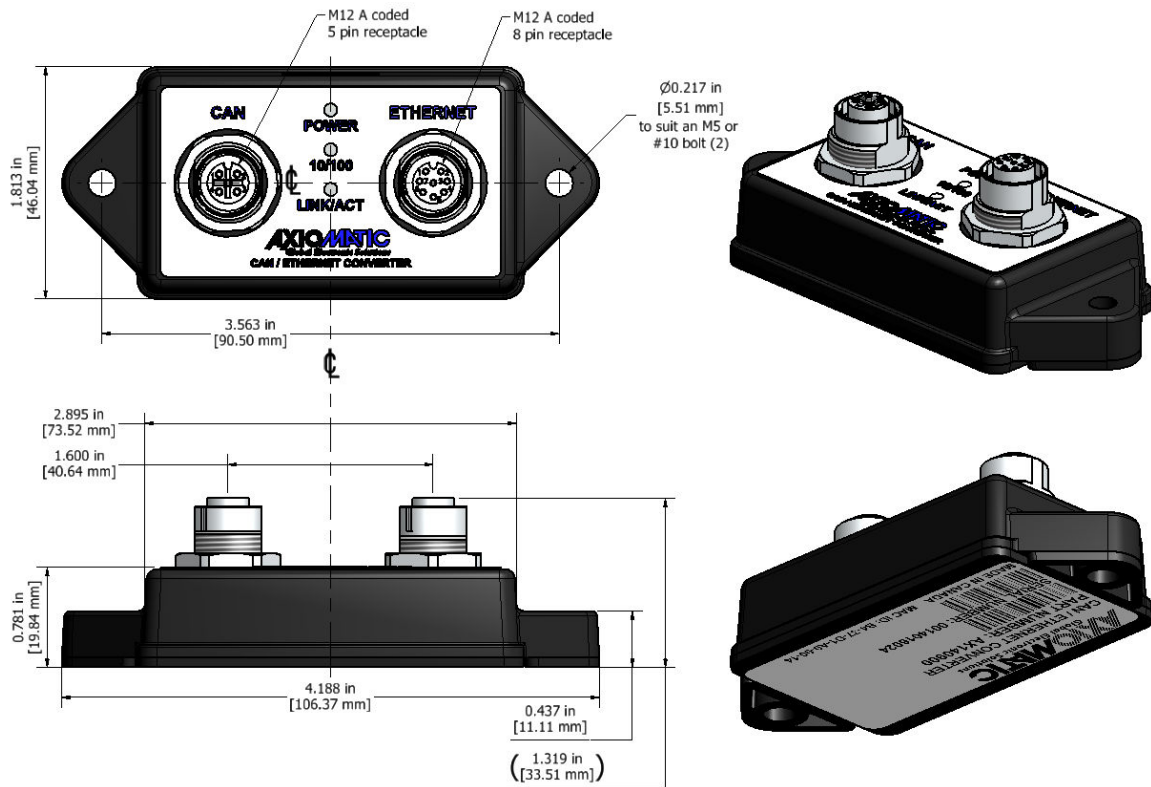

Figure 3.0. Dimensional Drawing

CANopen® is a registered community trademark of CAN in Automation e.V.

Form: TDAX140900-10/03/23