

I/O Module, 12 Inputs, 8 Analog and 1 Relay Outputs, CANopen®
10 Universal Signal Inputs
2 +5V/+10V References
1 Digital Input
1 Resistive Input
8 Analog Outputs
1 Relay Output
Isolated CAN (CANopen®)
P/N: AX030211

Features:

- 10 universal inputs are user selectable from the following.
 - 0-5V, 0-10V, 4-20 mA or 0-20 mA
 - Digital inputs for interface to switches, etc.
 - PWM signal, pulse or 16-bit counter inputs from sensors or diesel engine ECM's
- 2 voltage references can power external sensors
- 1 Resistive Input
- 1 Digital Input
- 8 analog outputs (0-5V, 0-10V, +/-5V, +/-10V, 0-20 mA, 4-20 mA)
- 1 Form C Relay Output
- 12/24VDC input power (nominal)
- 1 Isolated CAN (CANopen®)
- Rugged IP67 packaging and connectors
- EDS File
- CE/UKCA marking



Description: The controller features 1 Isolated CAN port for user-defined communications over the bus. It accepts up to 10 analog (0-5V, 0-10V, 0-20 mA or 4-20 mA), digital, PWM, Frequency or RPM inputs. Two voltage references (user configurable as +5V or +10V) are provided to power external sensors. A digital input and a resistive input allow for additional interfaces. Each input can be configured to measure the input value and send the data to a CANopen® network. The I/O module provides 8 analog outputs (0-5V, 0-10V, +/-5V, +/-10V, 0-20 mA, 4-20 mA) as well as 1 Form C relay output. Diagnostics messages are provided over the CAN network for the status of inputs or outputs. Rugged IP67 rated packaging in addition to a 12 or 24V power supply input section suits power generation and large engine applications.

Applications: Power generation, Cogeneration, Stationary power, Large engines

Ordering Part Numbers:

- Analog I/O, CANopen® P/N: **AX030211**
- Analog I/O, SAE J1939 250 kbps P/N: **AX030210**
- Analog I/O, SAE J1939 500 kbps P/N: **AX030210-01**
- Analog I/O, SAE J1939 1 Mbps P/N: **AX030210-02**

If the standard software or setpoint files are not suitable for your application, contact Axiomatic.

Accessories:

EDS File

- Reflashing Tool: Axiomatic Electronic Assistant KIT, P/Ns: **AX070502**, or **AX070506K**
- Mating plug kit: **AX070200** (8-pin and 40-pin, no key)

Block Diagram

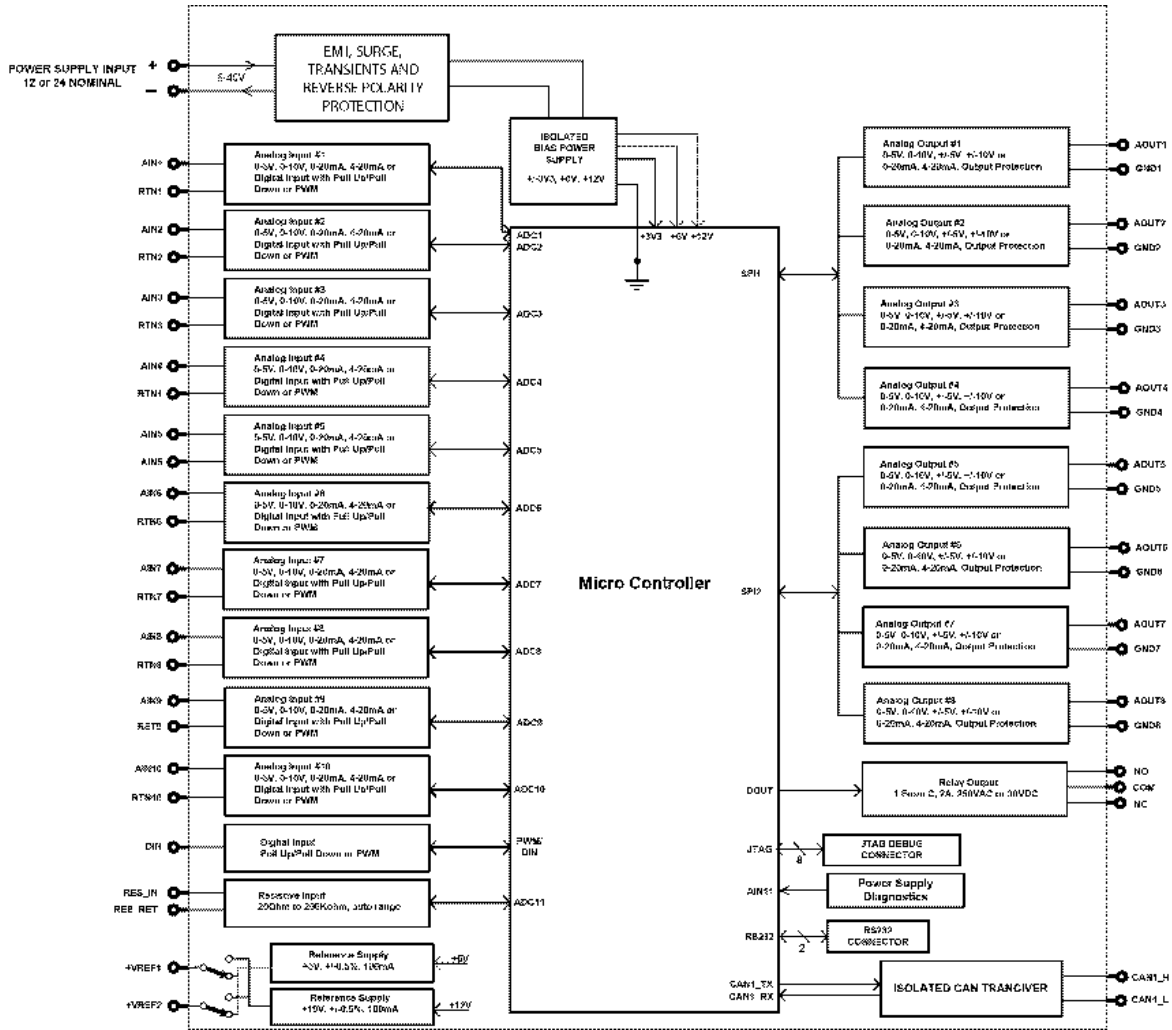

Technical Specifications:

Specifications are indicative and subject to change. Actual performance will vary depending on the application and operating conditions. Users should satisfy themselves that the product is suitable for use in the intended application. All our products carry a limited warranty against defects in material and workmanship. Please refer to our Warranty, Application Approvals/Limitations and Return Materials Process as described on <https://www.axiomatic.com/service/>.

Input Power

Power Supply Input - Nominal	12, 24VDC nominal (8...36 VDC power supply range) Surge protection is provided. If batteries are used, an alternator or other battery-charging device is necessary to maintain a stable supply voltage. Central suppression of any surge events should be provided at the system level. The installation of the equipment must include overcurrent protection between the power source and the module by means of a series connection of properly rated fuses or circuit breakers. Input power switches must be arranged external to the Axiomatic Control Module. Power input wiring should be limited to 10 meters.
Quiescent Current	300 mA at 12 Vdc Typical 155 mA at 24 Vdc Typical Inrush does not exceed 500 mA.
Protection	Reverse polarity protection is provided. Power supply input section protects against transients, surges (per IEC 60533, Table 4) and short circuits and is isolated from inputs. Undervoltage protection is provided and hardware shuts down at 7.5Vdc. Over-voltage protection is provided, and hardware shuts down at 41Vdc.

Inputs

Universal Signal Inputs	Up to 10 inputs are selectable by the user. All inputs, except for frequency, are sampled every 1ms. The user can select the type of filter that is applied to the measured data, before it is transmitted to the bus. The available filters are: <ul style="list-style-type: none"> • Filter Type 0 = No Filter • Filter Type 1 = Moving Average • Filter Type 2 = Repeating Average
Universal Signal Input Configuration	Up to 10 inputs are available. <i>Refer to Table 1.0.</i> Each input can be configured for any one of the following options. <ul style="list-style-type: none"> • Disable input • 0...5VDC or 0...10VDC • 4...20mA or 0...20mA • Digital input • PWM signal • Pulse (Hz or RPM) • 16-bit Counter
Input Protections	All inputs are protected against short circuits to GND or +Vcc.
Resistive Input	One resistive type input 1 Ohm resolution +/- 1 % accuracy Self-calibrating in the range of 25 Ohms to 250 kOhms
Analog GND	10 Analog GND connections are provided. The grounds are connected internally in the module. 1 Resistive Input GND connection is provided.
Voltage References	2 +5V references (sourcing up to 100 mA) +/- 0.1% or 2 +10V references (sourcing up to 100 mA) +/-0.2%
Input Scan Rate	1 mSec.
Digital Input	One Digital Input Active High or Active Low Configurable 10 kΩ pullup or pulldown resistor

Table 1.0 Description of Inputs

Input Type	Description
Analog Inputs	Up to 10 analog inputs are available. 0...5VDC or 0...10VDC 4...20mA or 0...20mA
Digital Inputs	Up to 10 digital inputs are available. The input accepted is active high or active low. Configurable 10 kΩ pullup or pulldown resistor
PWM Signal Inputs	Up to 10 PWM inputs are available to interface to a PWM signal from an ECM, PLC, etc. PWM Signal Frequency: 0.50 – 10,000 Hz Amplitude: 5-12V PWM Duty Cycle: 0 to 100%
Pulse Inputs	Up to 10 pulse inputs are available. This input counts the number of pulses over the period of the measuring window setpoint and calculates the frequency of the pulses. NOTE: The difference between Frequency and Counter mode is that the Frequency mode measures the number of pulses that occur in the Measuring Window period and calculates frequency, while the counter gives the period of time (in milliseconds) it takes for the number of pulses in the Measuring Window to be read at the input.
16-bit Counter Inputs	Up to ten 16-bit counter inputs are available. The input is configured to count pulses on the input until the value in the measuring window setpoint is reached.
Threshold Levels	For digital, PWM, pulse or counter inputs the voltage threshold levels are: <u>Input positive threshold (signal goes from low to high):</u> Min. 2.2V, typical 2.9V, max. 3.6V <u>Input negative threshold (signal goes from high to low):</u> Min. 1.2V, typical 1.7V, max. 2.3V
Input Accuracy	0-5V: +/- 0.01% 0-10V: +/- 0.01% 0-20mA or 4-20 mA: +/- 0.02% PWM, single channel: +/- 0.01% Frequency/RPM, single channel: +/- 0.2% 16-bit counter, single channel: +/- 3 mSec (@50 Hz)

Input Resolution	0-5V or 0-10V: 1 mV 0-20mA or 4-20 mA: 1µA
Input Impedance	Voltage 1 MOhm Current 124Ω PWM, frequency, 16-bit counter 1 MOhm

 **NOTE:** The input channels 3, 6, 7 and 8 have limited accuracy when used for detecting edges (Frequency / PWM measurements). The measurement accuracy can be enhanced using software filtering, but in case the Frequency or PWM duty cycle measurements need to have high accuracy, please avoid using these four channels.

 **NOTE:** The input channels 3 & 8 and 6 & 7 share the timer peripheral used for Frequency / PWM measurements. This limits the Frequency and PWM measurement configuration options available for these inputs. Both inputs of the pair need to be configured to use the same frequency detection range.

Outputs

Analog Outputs	8 Analog outputs 16-bit Digital to Analog User selectable (0-5V, 0-10V, +/-5V, +/-10V, 0-20 mA, 4-20 mA) Each analog output can be configured for one of the following options, and the properties and behavior of the output in each mode is described below in Table 2.0.
Output Accuracy	Voltage Output: +/- 0.2% Current Output: +/- 0.4%
Output Resolution	Voltage: 1 mV Current: 0.5 µA
Output Grounds	8 Analog Output GNDs are connected internally.
Output Adjust Rate	Approximately 1 mSec.
Short Circuit Protection	Individual short circuit protection is provided.
Other Protection	Each output is protected against shorts to GND or +Vcc.
Output Short Circuit Protection	Fully protected (all physical pins, all inputs, outputs and power)
Relay Output	1 Form C Relay NC 3 contact pins per output Maximum electrical endurance at contact: 0.25A @ 250Vac 0.5A @ 125Vac 0.24A @ 125Vdc 2A @ 30Vdc

Table 2.0 Analog Outputs	
0 to 5 Volts	The output is configured to drive a voltage output in the range of 0V to 5V. If feedback messages are used to send the output value to the bus, then the message will be sent with a resolution of 1mV/bit, and a 0mV offset.
-5 to 5 Volts	The output is configured to drive a voltage output in the range of -5V to 5V. If feedback messages are used to send the output value to the bus, then the message will be sent with a resolution of 1mV/bit, and a -5000mV offset.
0 to 10 Volts	The output is configured to drive a voltage output in the range of 0V to 10V. If feedback messages are used to send the output value to the bus, then the message will be sent with a resolution of 1mV/bit, and a 0mV offset.
-10 to 10 Volts	The output is configured to drive a voltage output in the range of -10V to 10V. If feedback messages are used to send the output value to the bus, then the message will be sent with a resolution of 1mV/bit, and a -10000mV offset.
0(4) to 20 Milliamps	The output is configured to source a current in the range of 0(4)mA to 20mA. If feedback messages are used to send the output value to the bus, then the message will be sent with a resolution of 1uA/bit, and a 0uA offset. Compliance voltage is up to 32Vdc.

General Specifications

Microprocessor	STM32F407ZG, ARM Cortex M4 32-bit, 1 Mbyte Flash Memory, 196 Kbyte SRAM
Control Logic	Standard embedded software is provided. <i>Refer to the user manual for details.</i> (Application-specific control logic is available on request.)

CAN Interface	1 CAN port (CANopen®) Digital isolation is provided for the CAN line.
Isolation	300Vrms Isolation for the CAN port
User Interface	EDS File Standard CANopen® tools
Reflashing Tool	Axiomatic Electronic Assistant KIT, P/Ns: AX070502, AX070506K
CAN (CANopen®)	The Axiomatic AX030211 is compliant with CANopen® protocol.
Operating Conditions	-40 to 85°C (-40 to 185°F)
Storage Temperature	-50 to 125°C (-58 to 257°F)
Protection	IP67, Unit is conformally coated in the housing. Tested to IP56 for marine type approval
Weight	2.20 lbs. (0.99 kg)
Compliance	CE marking Marine Type Approval: RINA
Vibration	MIL-STD-202G, Test 204D and 214A (Sine and Random) 10 g peak (Sine); 7.86 Grms peak (Random)
Shock	MIL-STD-202G, Test 213B, 50 g
Enclosure and Dimensions	Aluminum extrusion with stainless steel end plates. Gaskets are open cell neoprene. For dimensions, see below.

Dimensional Drawing

TE Deutsch DRC13-40PA

5.677 in [144.2 mm]
5.010 in [127.3 mm]
2.600 in [66.0 mm]

8-32 ground stud

.343 in [8.7 mm]

5.030 in [127.8 mm]
5.866 in [149.0 mm]

TE Deutsch DT13-08PA .157 in [4.0 mm]

2.874 in [73.0 mm]

.250 in [6.4 mm]
.500 in [12.7 mm]

DETAIL A
4 places

powder coated aluminum housing
closed cell neoprene gasket
stainless steel endcap

DETAIL C

unit label detail

AXIOMATIC
Global Electronic Solutions

I/O Module
12 Analog Outputs
1 Relay Output, Calltopen

P/N: AX030211
S/N: 007718008

40-pin CONNECTOR:
1-BATT+ 2-CAN_H 3-CAN_L 4-BATT- 5-DIGITAL IN
6-RELAY NO 7-RELAY NC 8-RELAY COM
9-RELAY NO 10-RELAY NC 11-RELAY COM 12-RELAY NO
13-RELAY NO 14-RELAY NC 15-RELAY COM 16-RELAY NO
17-RELAY NO 18-RELAY NC 19-RELAY COM 20-RELAY NO
21-RELAY NO 22-RELAY NC 23-RELAY COM 24-RELAY NO
25-RELAY NO 26-RELAY NC 27-RELAY COM 28-RELAY NO
29-RELAY NO 30-RELAY NC 31-RELAY COM 32-RELAY NO
33-RELAY NO 34-RELAY NC 35-RELAY COM 36-RELAY NO
37-RELAY NO 38-RELAY NC 39-RELAY COM 40-RELAY NO

Electrical Connections	1 8-pin receptacle (equivalent TE Deutsch P/N: DT13-08PA) Mating plug p/n: DT06-08SA with wedge W8S and sockets 0462-201-16141																	
	<table border="1"> <thead> <tr> <th>PIN#</th> <th>Description</th> </tr> </thead> <tbody> <tr> <td>1</td> <td>BATT +</td> </tr> <tr> <td>2</td> <td>CAN H</td> </tr> <tr> <td>3</td> <td>CAN L</td> </tr> <tr> <td>4</td> <td>BATT -</td> </tr> <tr> <td>5</td> <td>DIGITAL INPUT</td> </tr> <tr> <td>6</td> <td>Relay Output NO</td> </tr> <tr> <td>7</td> <td>Relay Output NC</td> </tr> <tr> <td>8</td> <td>Relay Output COM</td> </tr> </tbody> </table>	PIN#	Description	1	BATT +	2	CAN H	3	CAN L	4	BATT -	5	DIGITAL INPUT	6	Relay Output NO	7	Relay Output NC	8
PIN#	Description																	
1	BATT +																	
2	CAN H																	
3	CAN L																	
4	BATT -																	
5	DIGITAL INPUT																	
6	Relay Output NO																	
7	Relay Output NC																	
8	Relay Output COM																	

1 40-pin receptacle (equivalent TE Deutsch P/N: DRC13-40PA)
 Mating plug p/n: DRC16-40SA or DRC18-40SA with sockets 0462-201-16141

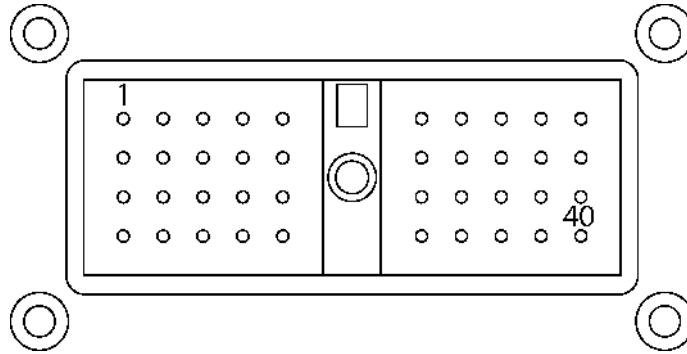

PIN#	Description
1	UNIVERSAL INPUT 2_GND
2	UNIVERSAL INPUT 4_GND
3	UNIVERSAL INPUT 6_GND
4	UNIVERSAL INPUT 8_GND
5	+V Reference 2
6	RESISTIVE INPUT_GND
7	ANALOG OUTPUT 1
8	ANALOG OUTPUT 2
9	ANALOG OUTPUT 3
10	ANALOG OUTPUT 4
11	UNIVERSAL SIGNAL INPUT 2
12	UNIVERSAL SIGNAL INPUT 4
13	UNIVERSAL SIGNAL INPUT 6
14	UNIVERSAL SIGNAL INPUT 8
15	UNIVERSAL INPUT 9_GND
16	RESISTIVE INPUT
17	ANALOG OUTPUT_GND
18	ANALOG OUTPUT_GND
19	ANALOG OUTPUT_GND
20	ANALOG OUTPUT_GND
21	UNIVERSAL INPUT 1_GND
22	UNIVERSAL INPUT 3_GND
23	UNIVERSAL INPUT 5_GND
24	UNIVERSAL INPUT 7_GND
25	UNIVERSAL SIGNAL INPUT 9
26	UNIVERSAL INPUT 10_GND
27	ANALOG OUTPUT 8
28	ANALOG OUTPUT 7
29	ANALOG OUTPUT 6
30	ANALOG OUTPUT 5
31	UNIVERSAL SIGNAL INPUT 1
32	UNIVERSAL SIGNAL INPUT 3
33	UNIVERSAL SIGNAL INPUT 5
34	UNIVERSAL SIGNAL INPUT 7
35	+V Reference 1
36	UNIVERSAL SIGNAL INPUT 10
37	ANALOG OUTPUT_GND
38	ANALOG OUTPUT_GND
39	ANALOG OUTPUT_GND
40	ANALOG OUTPUT_GND

Mating Plug Kit

Mating Plug Kit P/N: **AX070200**

This kit includes the following items. These items should also be available from a local TE Deutsch distributor.

NB. The sealing plugs are only needed in cases where not all of the 40 pins are used.

A crimping tool from TE Deutsch is required to connect wiring to the sockets, P/N: HDT 48-00 or equivalent (not supplied).

	TE Deutsch P/N	Description
	0462-201-16141	48 16AWG SOCKETS SOLID 16-20AWG WIRE 6mm
	114017	24 SEALING PLUGS SIZE 12-16 CAVITIES 12-18 AWG
	DRC16-40S	40-PIN PLUG, No Key
	DT06-08SA	DT SERIES PLUG 8 CONTACTS
	W8S	WEDGELOCK FOR DT 8 PIN PLUG
Grounding	<p>Protective Earth (PE) must be connected to the grounding stud to reduce the risk of electric shock. The conductor providing the connection should have a ring lug and wire larger than or equal to 4 mm² (12 AWG). The ring lug should be placed between the nut and a star washer. (To secure the ground strap, use an 8-32 "K-LOK" locknut, stainless steel, 3/8" O.D.)</p> <p>All chassis grounding should go to a single ground point designated for the machine and all related equipment.</p> <p>The ground strap that provides a low impedance path for EMI should be a ½ inch wide, flat, hollow braid, no more than 12 inches long with a suitable sized ring lug for the module's grounding lug. It may be used in place of the PE grounding conductor and would then perform both PE and EMI grounding functions.</p>	
Shielding	<p>The CAN wiring should be shielded using a twisted conductor pair. All wire shields should be terminated externally to the grounding lug on the mounting foot. The input wires should not be exposed for more than 2 inches (50 mm) without shielding. Shields can be ac grounded at one end and hard grounded at the opposite end to improve shielding. If the module is installed in a cabinet, shielded wiring can be terminated at the cabinet (earth ground), at the entry to the cabinet or at the module.</p>	
CAN Wiring	<p>The CAN port is electrically isolated from all other circuits. The isolation is SELV rated with respect to product safety requirements. Refer to the CAN specification for more information.</p> <p>Use CAN compatible cabling rated for engine use.</p> <p>Shielded CAN cable is required. The module provides the CAN port shield connection ac coupled to chassis ground. The chassis ground stud located on the mounting foot must be tied directly to Earth Ground.</p>	
Network Construction	<p>Axiomatic recommends that multi-drop networks be constructed using a "daisy chain" or "backbone" configuration with short drop lines.</p>	
Termination	<p>It is necessary to terminate the network with external termination resistors. The resistors are 120 Ohm, 0.25W minimum, metal film or similar type. They should be placed between CAN_H and CAN_L terminals at both ends of the network.</p>	
Mounting	<p>Mounting ledges include holes sized for ¼ inch or M6 bolts. The bolt length will be determined by the end-user's mounting plate thickness. Typically, ¾ inch (20 mm) is adequate.</p> <p>If the module is mounted without an enclosure, it should be mounted vertically with connectors facing left and right to reduce likelihood of moisture entry.</p> <p>The CAN wiring is considered intrinsically safe. The power wires are not considered intrinsically safe and so in hazardous locations, they need to be located in conduit or conduit trays at all times. The module must be mounted in an enclosure in hazardous locations for this purpose.</p> <p>No wire or cable harness should exceed 30 meters in length. The power input wiring should be limited to 10 meters.</p> <p>All field wiring should be suitable for the operating temperature range of the module.</p> <p>Install the unit with appropriate space available for servicing and for adequate wire harness access (6 inches or 15 cm) and strain relief (12 inches or 30 cm).</p>	

Note: CANopen® is a registered community trademark of CAN in Automation e.V.

Form: TDAX030211-11/23/23