

7 Digital In, 6 Digital & 4 LED Outputs Controller

7 Digital Inputs for Switches and Proximity Sensors

6 Outputs for On/Off Hydraulic Valves (up to 4A)

4 Sourcing LED Outputs

1 CAN (SAE J1939)

with Axiomatic Electronic Assistant

P/N: AX022950

Features:

- 12VDC or 24VDC nominal power input
- 7 Digital Inputs for Switches and Proximity Sensors
- 6 Digital Outputs up to 4A for On/Off Hydraulic Valves (4 high sourced and 2 low sourced)
- 4 Sourcing LED Outputs (up to 50 mA)
- 1 CAN (SAE J1939)
- Rugged IP67 packaging and connectors
- Rugged design for EMC compliance
- Suitable for the environmental and vibration requirements of off-highway equipment applications
- The **Axiomatic Electronic Assistant** together with an Axiomatic USB-CAN converter links the PC to the CAN bus for user configuration.
- Flexible user programming for application-specific control logic via the CAN based Axiomatic Electronic Assistant.



Applications:

The controller is designed to meet the rugged demands of mobile off-highway equipment applications.

Ordering Part Numbers:

SAE J1939 version Controller: **AX022950**

Accessories:

PL-DTM06-12SA-12SB Mating Plug Kit

Axiomatic Electronic Assistant Configuration KIT, P/Ns: **AX070502**, **AX070505K**, or **AX070506K**

Technical Specifications:

Specifications are indicative and subject to change. Actual performance will vary depending on the application and operating conditions. Users should satisfy themselves that the product is suitable for use in the intended application. All our products carry a limited warranty against defects in material and workmanship. Please refer to our Warranty, Application Approvals/Limitations and Return Materials Process as described on <https://www.axiomatic.com/service/>.

Inputs

Power Supply Input - Nominal	12VDC or 24VDC nominal (8...32 VDC power supply range)
Protection	Reverse polarity protection is provided. Overvoltage protection up to 200V is provided.

CAN	SAE J1939 Commands CANopen® is available on request.
-----	---

Digital Signal Inputs	7 Digital inputs Configurable as Active High or Active Low 5V CMOS, +Vps (12VDC or 24VDC) All inputs have a 2kΩ pull-down resistor. Input functionality is user selectable. Inputs are sampled multiple times per millisecond. Protected against shorts to GND or +Vcc
GND Reference	One provided

Outputs

CAN	SAE J1939 Messages
High Sourced Outputs	4 independent software controlled outputs: On/Off Digital types Current sensing, grounded load High side sourcing up to 4A
Low Sourced Outputs	2 independent software controlled outputs: On/Off Digital types Low side sinking up to 4A
Signal Outputs	4 Sourcing Outputs (50 mA) for LED's
Protection	Fully protected against short circuit to ground or +Vcc Grounded short circuit protection will engage at 4.5A +/- 0.5A. Unit will fail safe in the case of a short-circuit condition and is self-recovering when the short is removed.

General Specifications

Quiescent Current	90 mA @ 24V; 140 mA @ 12V Typical
Microprocessor	32-bit, 512 KByte or larger program memory Safety Microcontroller TMS570LS0714
Diagnostics	Each input and output channel can be configured to send diagnostic messages to the J1939 CAN network if the I/O goes out of range. Diagnostic data is stored in a non-volatile log. Refer to the User Manual for details.
Additional Fault Feedback	There are several types of faults that the controller will detect and provide a response: unit power supply undervoltage and overvoltage, microprocessor over temperature and lost communication. They can be sent to the J1939 CAN bus.
Compliance	EMC compliant Designed for the environmental and vibration requirements of off-highway equipment applications
Control Logic	User programmable functionality using the Axiomatic Electronic Assistant service tool. The controller consists of a set of internal functional blocks, which can be individually programmed and arbitrarily connected to achieve the required system functionality. Each functional block is independent and has its own set of parameters, or setpoints, used to control its functionality. The setpoints are accessible through CAN using Axiomatic Electronic Assistant (EA) software.
Communications	1 CAN port (SAE J1939)

User Interface	The Axiomatic Electronic Assistant for <i>Windows</i> operating systems (P/Ns: AX070502 AX070505K, or AX070506K) It comes with a royalty-free license for use.
Enclosure	High Temperature Nylon PCB Enclosure - (equivalent TE Deutsch P/N: EEC-325X4B) Refer to Figure 1.0. 4.63 x 5.25 x 1.42 inches 117.60 x 133.45 x 35.98 mm (W x L x H excluding mating plugs)

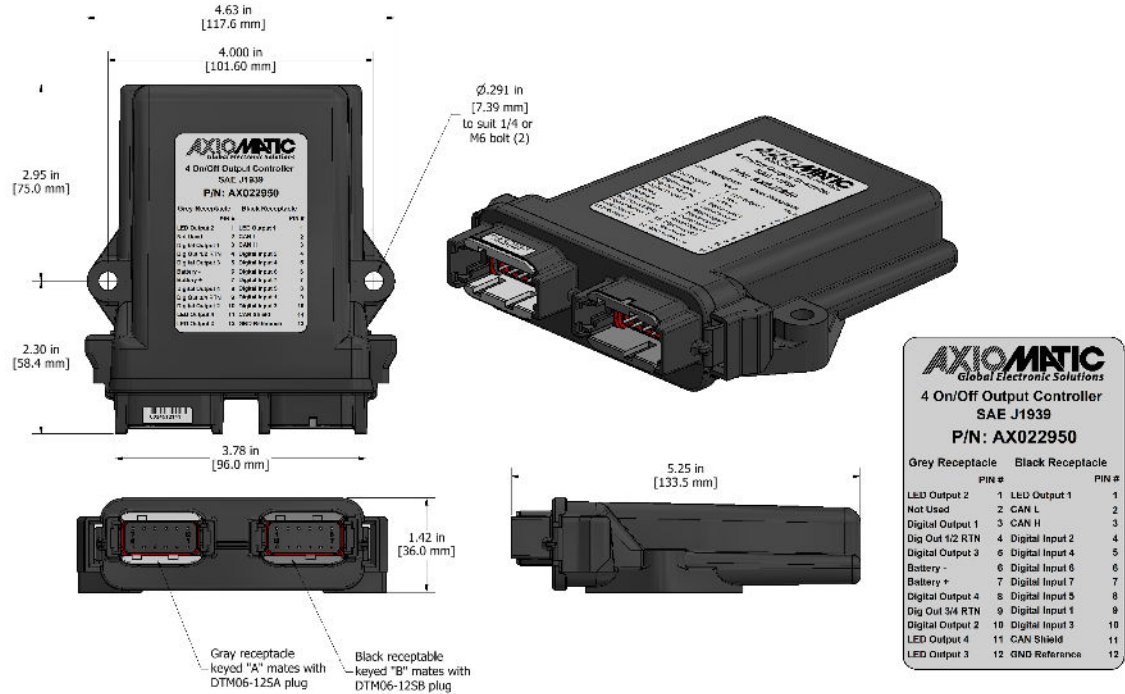

Figure 1.0 – Dimensional Drawing

Protection	IP67 rating for the product assembly
Weight	0.55 lbs. (0.250 kg)
Temperature Rating	Operating: -40 to 85°C (-40 to 185°F) Storage: -50 to 105°C (-58 to 221°F)
Electrical Connections	24-pin receptacle (equivalent TE Deutsch P/N: DTM13-12PA-12PB-R008) Mating plug - equivalent to the TE Deutsch P/Ns: DTM06-12SA and DTM06-12SB, with 2 wedgelocks (WM12S) and 24 contacts (0462-201-20141). 20 AWG wire is recommended for use with contacts 0462-201-20141. Use dielectric grease on the pins when installing the controller. Key Arrangement B (black) Key Arrangement A (grey) FRONT VIEW 24 PIN RECEPTACLE

Grey Connector		Black Connector	
Pin #	Function	Pin #	Function
1	LED Output 2	1	LED Output 1
2	N/A	2	CAN_L
3	High Digital Output 1	3	CAN_H
4	Low Digital Output 1	4	Digital Input 2
5	High Digital Output 3	5	Digital Input 4
6	Battery -	6	Digital Input 6
7	Battery +	7	Digital Input 7
8	High Digital Output 4	8	Digital Input 5
9	Low Digital Output 2	9	Digital Input 1
10	High Digital Output 2	10	Digital Input 3
11	LED Output 4	11	CAN_Shield
12	LED Output 3	12	GND Reference

Installation	<p>Mounting holes sized for ¼ inch or M6 bolts. The bolt length will be determined by the end-user's mounting plate thickness. The mounting flange of the controller is 0.63 inches (16 mm) thick.</p> <p>If the module is mounted without an enclosure, it should be mounted to reduce the likelihood of moisture entry.</p> <p>Install the unit with appropriate space available for servicing and for adequate wire harness access (6 inches or 15 cm) and strain relief (12 inches or 30 cm).</p> <p>The CAN wiring is considered intrinsically safe. The power wires are not considered intrinsically safe and so in hazardous locations, they need to be located in conduit or conduit trays at all times. The module must be mounted in an enclosure in hazardous locations for this purpose.</p> <p>All field wiring should be suitable for the operating temperature range of the module.</p> <p>All chassis grounding should go to a single ground point designated for the machine and all related equipment.</p>
Network Termination	<p>It is necessary to terminate the network with external termination resistors. The resistors are 120 Ohm, 0.25W minimum, metal film or similar type. They should be placed between CAN_H and CAN_L terminals at both ends of the network.</p>

CANopen® is a registered community trademark of CAN in Automation e.V.

Form: TDAX022950-06/14/23