

TECHNICAL DATASHEET #TDAX020509
QUAD VALVE CONTROLLER
P/N: AX020509

Multiple Digital, Analog or PWM Command Inputs
1 +5V, 50 mA Voltage Reference
4 Independent Proportional Outputs and 1 On/Off Output
1 RS-232, 1 CAN port
Standard Open Loop Control Profiles

with Service Tool Software for PC (CD-AX020501)

Applications:

The quad valve controller provides precise, repeatable control of 4 proportional solenoids and 1 on/off solenoid. User configurable open loop control profiles in the embedded software permit control of proportional poppet or spool valves. PWM signal inputs or analog voltage or current inputs are accepted for interface to a PLC, Engine Control Module or command potentiometers. Multiple switched inputs are provided to suit a range of applications. A RS-232 port permits user configuration, diagnostics and service via the PC-based Service Tool. A controller with 1 CAN port (SAE J1939 or CANopen®) is also available.

The controller is designed for harsh operating environments. Typical applications can include:

- Industrial, off-highway (mobile) and marine applications for the control of hydraulic valves
- Interface with a diesel engine's electronic control module PWM signal to drive accessories
- Transmission controls
- Vehicle Traction control
- Closed loop control of hydraulic valves (on request)



Features:

- Accepts voltage or current analog inputs (up to 4), 0-5V, 0-10V, 4-20 mA or 0-20 mA
- Provides a +5V, 50 mA reference voltage to power an input device
- Choice of digital inputs for interface to switches, etc. (2 in control logic, up to 6 available on h/w)
- Interfaces to up to 2 PWM signal inputs from sensors, PLC's or ECM's
- Independent outputs for 4 proportional solenoids (0...1.5A or 2A) and 1on/off valve (≤ 5 A)
- Robust 8...36VDC power supply interface with reverse polarity protection
- Thermal overload and overvoltage protection provided
- Rugged IP67 rated packaging with plug-in connections
- 1 RS-232 port and 1 CAN port (SAE J1939)
- Operational from -40 to 85°C (-40 to 185°F)
- CE type approval for the 2004/104/EC Directive (EMC)
- Embedded software with standard open loop control profiles for positive slope proportional response to various command signals or a joystick with enable switch
- A PC-based Service Tool provides for user configuration, software upload, writing settings to additional quad controllers and performing diagnostics as well as data logging to Excel for analysis.

Ordering Part Numbers:

Quad Valve Controller – Standard version: **AX020509** (includes Service Tool AX020501)

OEM versions with application-specific software or configuration files are available on request.

Service Tool Software: **CD-AX020501** (requires a wire harness with a RS-232 connector)

Mating wire harness assembly with RS-232 connector: **AX070001** (standard version)

AX070002 (version for parallel output configuration)

Mating plug kit with RS-232 connector: **AX070000** (mating plugs, DB-9, no wires)

Block Diagram:

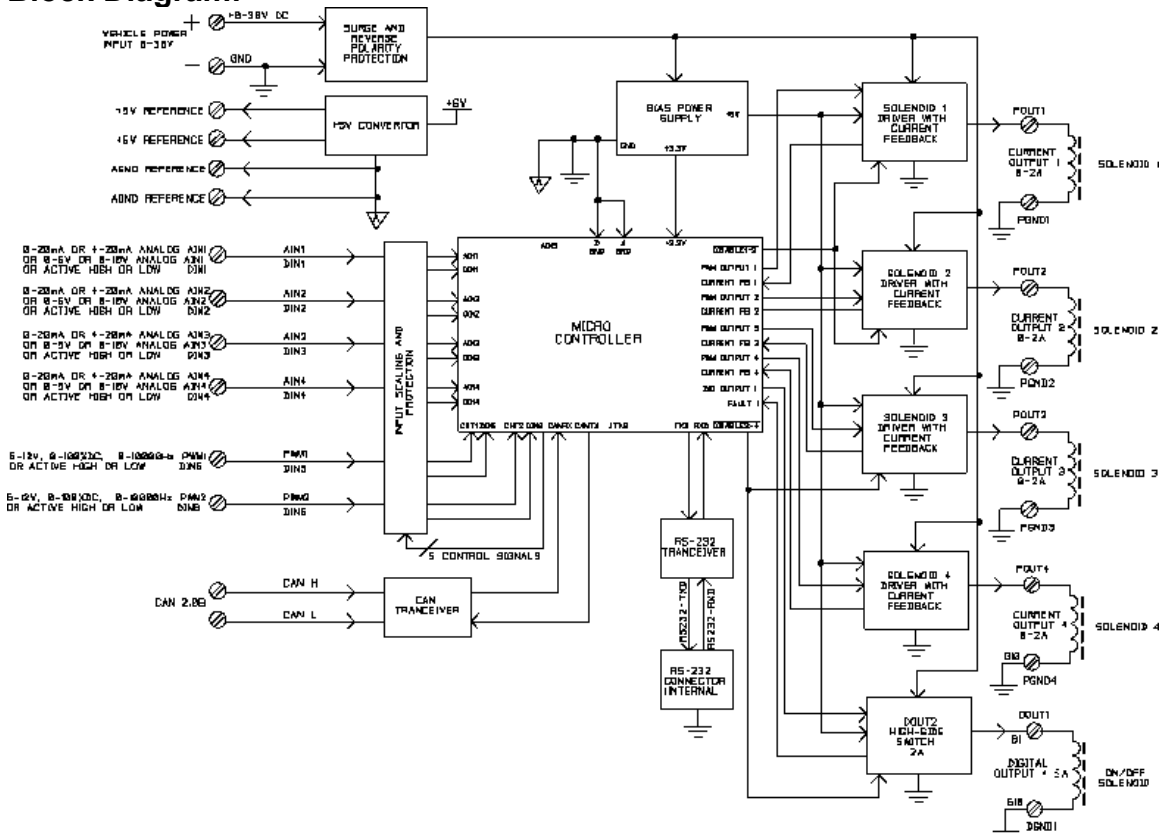

Notes: Model shown above depicts full hardware capability. In model AX020509, the RS232 port is on the black 12 pin external connector. The 2nd +5V reference and analog GND are not available in this model.

Control Logic:

The standard model has some 'built in' control logic to accommodate typical applications. The system parameters can be configured via RS-232 using a Service Tool to setup the controller for the application.

These parameters are:

- Command Type (logic)
- Enable Control (logic)
- Input Type
- Input Parameters
- Output Parameters (min, max, ramps, dither)

Technical Specifications:

Specifications are indicative and subject to change. Actual performance will vary depending on the application and operating conditions. Users should satisfy themselves that the product is suitable for use in the intended application. All our products carry a limited warranty against defects in material and workmanship. Please refer to our Warranty, Application Approvals/Limitations and Return Materials Process as described on <https://www.axiomatic.com/service/>.

General Specifications

Microprocessor	Motorola MC56F8366
Response Time	50 mSec
Control Logic	Standard embedded software is provided. Parameters are user configurable. Refer to Table 1 and Table 2. (Application-specific control logic is available on request.)
CAN Interface	1 CAN port is provided. Other models feature CAN bus as well. AX020507 (SAE J1939) or AX020506 (CANopen®)
User Interface (Service Tool)	A Service Tool is used for parameter configuration, software upgrade + diagnostics for the AX020509 quad controller. Service Tool Software: AX020501 is provided with the controller + requires a RS-232 cable for the PC. It comes with a royalty-free license for use. The controller's RS232 port interfaces to a serial port (i.e. COM1) on a PC (115200 Baud Rate, N81, Xon/Xoff Flow Control). If the Axiomatic wire harness with a built-in RS-232 connector is not used, then the end user can make a RS-232 cable with the following pinout. Controller Black Connector, Pin 7 -> TXD -> female DB-9 Pin 2 Controller Black Connector, Pin 8 -> RXD -> female DB-9 Pin 3 Controller Black Connector Pin 9 -> GND -> female DB-9 Pin 5
Electrical Connections	Refer to Table 3. 24-pin receptacle (equivalent TE Deutsch P/N: DTM13-12PA-12PB-R008) Mating plugs kits are available on request and include the TE Deutsch equivalents: DTM06-12SA and DTM06-12SB with 2 wedgelocks (WM12S), and 24 contacts (0462-201-20141). 20 AWG wire is recommended for use with contacts 0462-201-20141. Use dielectric grease on the pins when installing the controller.
Packaging and Dimensions	High Temperature Nylon PCB Enclosure (equivalent TE Deutsch P/N: EEC-325X4B) 4.62 x 5.24 x 1.43 inches 117.42 x 133.09 x 36.36 mm (W x L x H excluding mating plug)
Operating Conditions	-40 to 85°C (-40 to 185°F)
Protection	IP67; Unit is conformal coated within the housing.
Weight	0.55 lbs. (0.25 kg)
Approvals	CE type approval for the 2004/104/EC Directive (EMC)

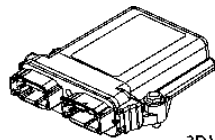

3D VIEW
Housing with 24 Pin Receptacle

HOUSING DIMENSIONS

Housing Material: High Temperature Nylon (Black)

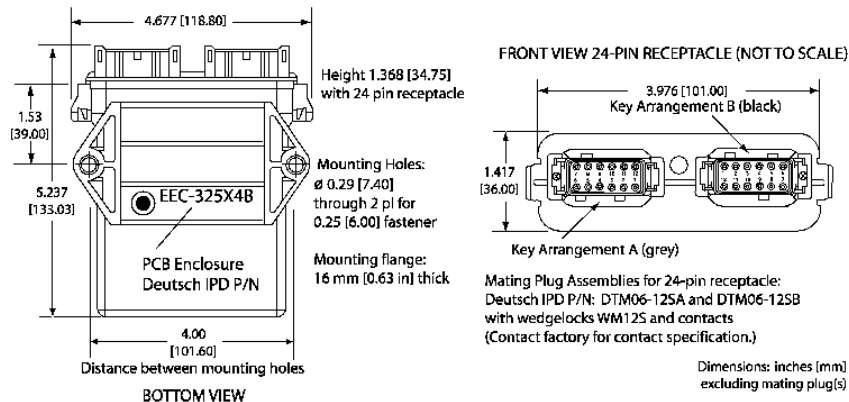

Connections

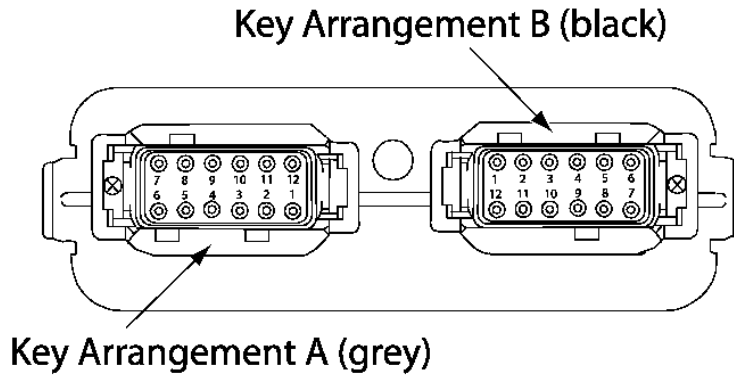

FRONT VIEW 24 PIN RECEPTACLE

Table 3 - Pinout: AX020509 (with RS-232 port)

Grey Connector PIN #	Function	Black Connector PIN #	Function
12	Power -	6	Analog In 4 / Digital In 4 (not used in standard software)
1	Power +	7	RS-232 Transmit (See Notes.)
11	Proportional Solenoid 1-	5	Analog In 3 / Digital In 3 (not used in standard software)
2	Proportional Solenoid 1+	8	RS-232 Receive (See Notes.)
10	Proportional Solenoid 2-	4	Analog In 2 / Digital In 2 (ENABLE control when PWM command type is selected.)
3	Proportional Solenoid 2+	9	Analog GND (and RS-232 GND)
9	Proportional Solenoid 3-	3	Analog In 1 / Digital In 1 (Controls the digital output when PWM command type is selected.)
4	Proportional Solenoid 3+	10	+5V Reference
8	Proportional Solenoid 4-	2	CAN_L
5	Proportional Solenoid 4+	11	PWM In 1 / Digital In 5 (Controls the digital output when Analog command type is selected.) (See Notes.)
7	Digital Solenoid -	1	CAN_H
6	Digital Solenoid +	12	PWM In 2 / Digital In 6 (ENABLE control when Analog command type is selected.) (See Notes.)

Notes: To ground a PWM input, use the analog GND connection pin.
Active high digital inputs can be connected to the +5V reference.
Active low inputs can be grounded to the analog GND connection pin.

Use a RS-232 cable with the following pinout to make this connection.
Controller Black Connector, Pin 7 -> TXD -> female DB-9 Pin 2
Controller Black Connector, Pin 8 -> RXD -> female DB-9 Pin 3
Controller Black Connector Pin 9 -> GND -> female DB-9 Pin 5

Input Specifications

Refer to the block diagram for an illustration of the input options available.

Power Supply Input - Nominal	12 or 24VDC nominal 8...36 VDC power supply range NB. The maximum total current draw permitted on the power supply input pins is 6 Amps @ 24VDC.
Surge and Reverse Polarity Protection	Provided
All Inputs	Up to 6 inputs are selectable by the user. (Refer to the block diagram for the arrangement of inputs available.) The standard software package for control profiles is user configurable as command type shown below. 2- PWM 2- 0-5V 2- 0-10V 4- 0-5V 4- 0-10V 2- 0-20 mA 2- 4-20 mA 4- 0-20 mA 4- 4-20 mA CAN All digital inputs are independently configurable as shown below. DINX_ActiveLevel - Active Low, GND = ON or Active High +V = ON or Active Low, GND = OFF or Active High, +V = OFF
Analog Inputs	Up to 4 universal analog inputs are available. 0...5VDC or 0...10VDC 4...20mA or 0...20mA (User must select all voltage or all current inputs.) Accuracy of 0-5V input (inputs 1-4) is +/- 50 mV. Accuracy of 0-10V input (1-4) is +/-100 mV.
Analog Ground	Model AX020509: One analog ground connection is provided.
Digital Inputs	2 digital inputs are used with up to 6 available in the h/w. (Refer to block diagram). See Table 1 for the control logic of the digital inputs/outputs. All digital inputs are independently configurable as shown below. DINX_ActiveLevel - Active Low, GND = ON or Active High +V = ON or Active Low, GND = OFF or Active High, +V = OFF
PWM Signal Input	Up to 2 PWM inputs are available. (Refer to the block diagram and Table 1.) Interfaces to a PWM signal from an Engine Control Module, PLC or other. PWM Signal Frequency: 0 – 10,000 Hz Amplitude: 5-12V PWM Duty Cycle: 0 to 100% (NB. At ≤ 1 kHz the input accuracy is +/- 3%. At > 1 kHz, it is +/- 5%.)
Enable	The enable input can be wired to a deadman switch on a joystick for example. Not used (default) Option 1, Enable ON, all outputs are OFF Option 2, Enable ON, proportional outputs are OFF, digital control input drives digital output Option 3, Enable ON, proportional output ramps to zero, digital control input drives digital output

Table 1 - Control Logic – Input/Output Combinations

Command type is user configurable in the controller AX020509.

For application-specific s/w contact Axiomatic.

AX020509 Model		
Joystick Interface Profile	2 PWM inputs, 2 digital inputs or 2 analog inputs, 2 digital inputs	PWM 1 → P Out 1 & 2 PWM 2 → P Out 3 & 4 DIG IN 1 → D Out 1 DIG IN 2 → ENABLE Control or Analog In 1 → P Out 1 & 2 Analog In 2 → P Out 3 & 4 DIG IN 5 → D Out 1 DIG IN 6 → ENABLE Control
Positive Slope Proportional Response Profile	4 analog inputs, 2 digital inputs	Analog In 1 → P Out 1 Analog In 2 → P Out 2 Analog In 3 → P Out 3 Analog In 4 → P Out 4 DIG IN 5 → D Out 1 DIG IN 6 → ENABLE Control

- Changing the command type re-initializes the non-volatile memory (NVM) to the new input type default values. This is true, even if the input type has not changed (i.e. Two 0-5V to Four 0-5V)
- If the command type does not change, the NVM does not change.
- The output parameters do not change when the command type changes.

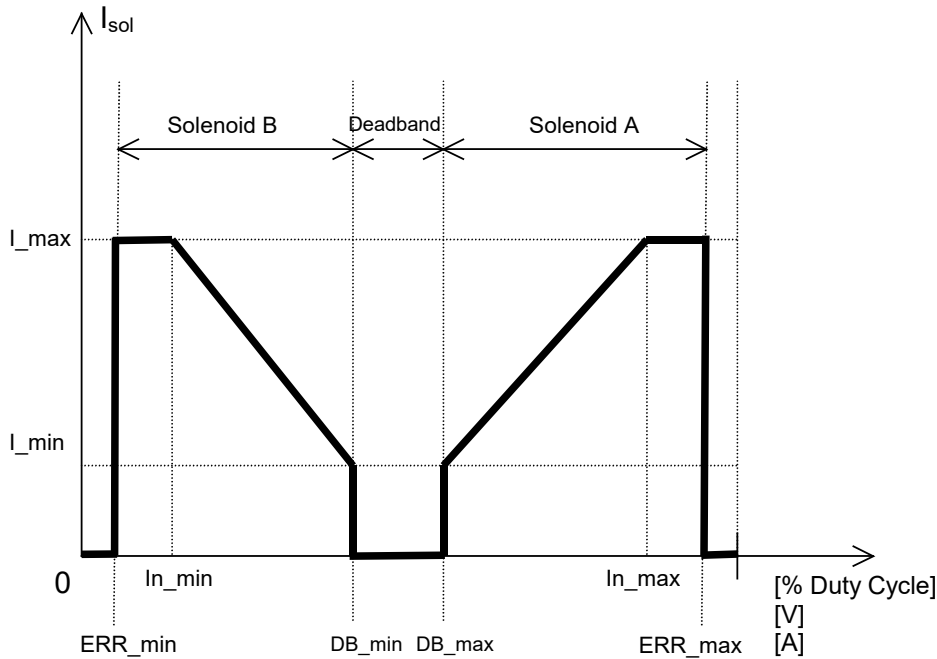

Fig. 1. Performance Characteristics – Joystick Profile – single channel shown
NB. Breakpoints are not shown.

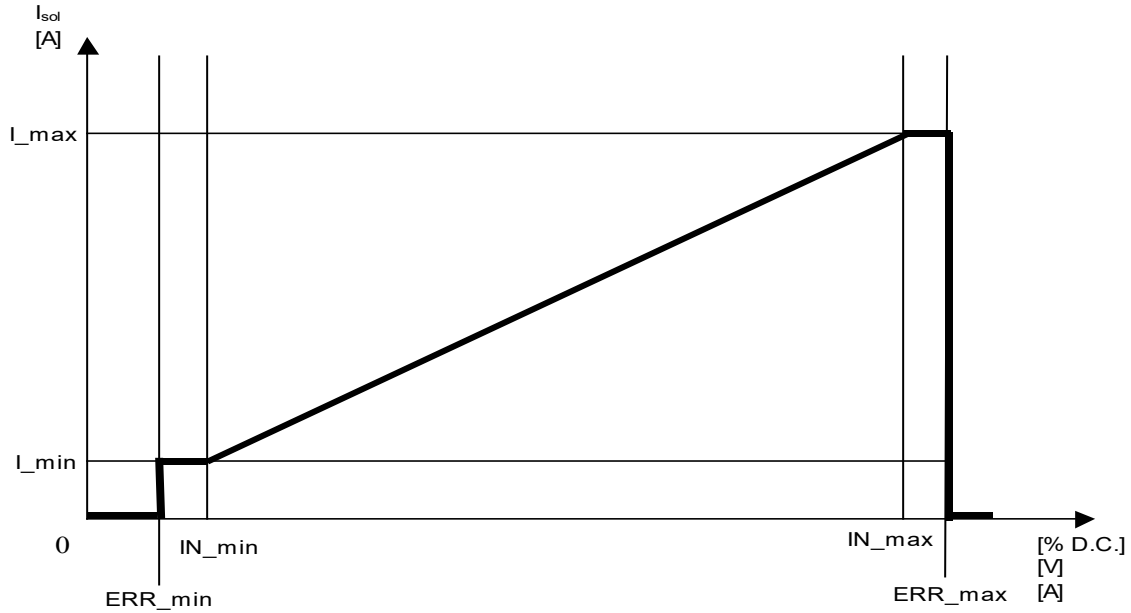

Fig. 2. Performance Characteristics – Positive Slope Proportional Response Profile – single channel shown

Note: For proportional poppet valve applications, a dual slope is user configurable.

Output Specifications

Maximum Current Output (High frequency PWM output)	<p>Four independent proportional outputs One digital output ($\leq 5A$) (Proportional outputs can be changed to up to 4 on/off outputs on request.) Overcurrent protection is provided. Short circuit protection is provided.</p> <p>I-max is configurable for each proportional output. Dual input command type: 0 to 2,000 mA Four input command type: 0 to 1,500 mA NB. The maximum total current draw permitted on the power supply input pins is 6 Amps @ 24VDC. For proportional poppet valve applications, a dual slope is user configurable.</p>
Proportional Output Current Adjustments	<p>0- Imax Both minimum and maximum current settings is user configurable. See Table 2.</p>
Superimposed Dither	<p>Dither adjustments are configurable for each channel. <u>Dither Amplitude:</u> 75 mA (factory default) Adjustable from 0-200 mA <u>Dither Frequency:</u> 200 Hz (factory default) Adjustable from 50-400 Hz</p>
Ramp Rates	<p>Ramp adjustments are configurable for each channel. 1,500 msec (default) Adjustable from 0 to 10,000 msec (10 sec.).</p>
Output Accuracy	+/-3%
Error Conditions	If an error on the input is detected, the output of the controller shuts off.
Output Reference Voltages	<p>Model AX020509: One +5V reference, 50 mA NB. Reference voltage is available if digital inputs are active high, which is the default for a voltage input command type.</p>

Table 2 - Configurable Parameters (AX020509)

Standard defaults are provided with the Service Tool. The user can change the settings to suit their application.

Parameter	Default	Range of Adjustment and Logic
PWM Input	See input parameters below.	0 to 100% Duty Cycle
Voltage Input	See input parameters below.	0 to 5V or 0-10V
Current Input	See input parameters below.	0-20 mA or 4-20 mA
Control Parameters		
Command Input Type	2- 0-5V	2- PWM 2- 0-5V 2- 0-10V 4- 0-5V 4- 0-10V 2- 0-20 mA 2- 4-20 mA 4- 0-20 mA 4- 4-20 mA CAN
Enable Input	Not Used	Active Low, GND = ON (ENABLE) Active High +V = ON (ENABLE) Active Low, GND = OFF (DISABLE) Active High, +V = OFF (DISABLE)
Digital Input that controls Digital Output	Refer to individual input parameters below. Refer to Table 1 for appropriate DIN#.	Active Low, GND = ON (DOUT ON) Active High +V = ON (DOUT ON) Active Low, GND = OFF (DOUT OFF) Active High, +V = OFF (DOUT OFF)
Input Parameters		
Minimum Input Error In_ERR_Min	PWM: 1% 0-5V: 0.2V 0-10V: 0.2V 0-20 mA: 0 mA 4-20 mA: 1 mA	If the input is < this value, an error is flagged and all outputs are OFF.
Minimum Input In_Min	PWM: 5% 0-5V: 0.5V 0-10V: 0.5V 0-20 mA: 0 mA 4-20 mA: 4 mA	If the input is < or = to this value, the correspondent output is at maximum or minimum depending on command type.
Minimum Input Breakpoint In_Break_Min This is used only in a dual profile (1 input controls two outputs).	PWM: 25% 2 - 0-5V: 1.4V 2 - 0-10V: 2.6V 2 - 0-20 mA: 4.5 mA 2 - 4-20 mA: 7.5 mA	Any measured input < or = to this value (but > or = to In_Min), causes a linear proportional response in POUTB between PoutB_Imax and PoutB_Ibreak.
Input Breakpoint In_Break This is used only in a single profile (1 input controls 1 output.)	4 - 0-20 mA : 10 mA 4 - 4-20 mA: 12 mA 4 - 0-10V: 5.0V 4 - 0-5V: 2.5V	Any measured input < or = to this value (but > or = to In_Min), causes a linear proportional response in POUTY between PoutY_Imin and PoutY_Ibreak.
Minimum Input Deadband In_DB_Min This is used only in a dual profile (1 input controls two outputs).	PWM: 45% 2 - 0-5V: 2.3V 2 - 0-10V: 4.7V 2 - 0-20 mA: 9 mA 2 - 4-20 mA: 11 mA	If the input is > this value and < In_DB_Max, all outputs are OFF.
Maximum Input Deadband In_DB_Max This is used only in a dual profile (1 input controls two outputs).	PWM: 55% 2 - 0-5V: 2.7V 2 - 0-10V: 5.3V 2 - 0-20 mA: 11 mA 2 - 4-20 mA: 13 mA	If the input is < this value and > In_DB_Min, all outputs are OFF. If this value is set to the highest possible # for the input range, then this parameter is ignored.
Maximum Input Breakpoint In_Break_Max This is used only in a dual profile (1 input controls two outputs).	PWM: 75% 2 - 0-5V: 3.6V 2 - 0-10V: 7.4V 2 - 0-20 mA: 15.5 mA 2 - 4-20 mA: 16.5 mA	Any measured input > or = to this value (but < or = to In_Max), causes a linear proportional response in POUTA between PoutA_Ibreak and PoutA_Imax.

Maximum Input In_Max	PWM: 95% 0-5V: 4.5V 0-10V: 9.5V 0-20 mA: 20 mA 4-20 mA: 20 mA	In the input is > or = to this value, the corresponding output is at maximum.
Maximum Input Error In_ERR_Max	PWM: 99% 0-5V: 4.8V 0-10V: 9.8V 0-20 mA: 20 mA 4-20 mA: 20 mA	If the input is > this value, an error is flagged and all outputs are OFF.
Output Parameters		
Dither PoutY_Frequency PoutY_Amplitude	200 Hz 75 mA	50 to 400 Hz 0 to 200 mA
Ramps PoutY_Ramp Up PoutY_RampDown	1500 msec 1500 msec	0 to 10,000 msec Ramp up and ramp down are configurable for each proportional output.
I-min PoutY_Imin	0 mA	Configurable for each proportional output. 0 to I _{max}
Breakpoint Current PoutY_Ibreak	750 mA	Configurable for each proportional output. 0 to I _{max}
I-max PoutY_I _{max}	1500 mA	Configurable for each proportional output. Dual input command type: 0 to 2,000 mA Four input command type: 0 to 1,500 mA

AX020501 Service Tool:

The Service Tool is a graphical user interface for easy configuration (tuning) of the controller. It also provides a diagnostic tool for troubleshooting and remote analysis of the operating data.

The service tool is provided with controller AX020509. It comes with a royalty-free license for use.

A RS-232 cable is required for connection from the controller to a COM port on a PC or laptop computer. (Note: For PC's with a USB port, use a commercially available USB-RS232 adaptor cable.)

System Requirements:

Operating Software: Windows 2000, XP

Port: Serial port, R232 (default is COM1)

RS232 pin-out: TXD, RXD, GND (Refer to the Connections section for the pinout details.)

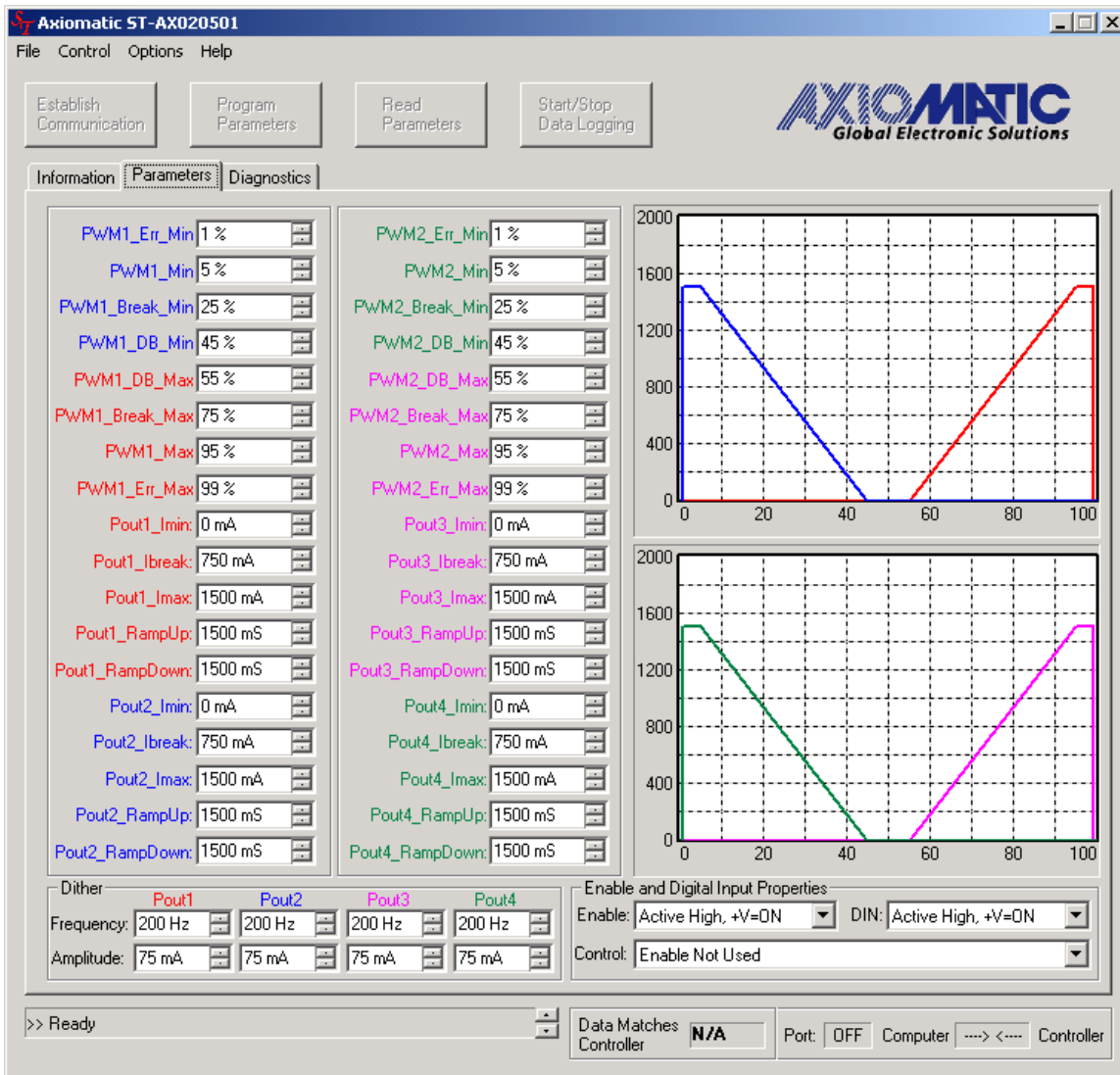

Sample screen capture showing configurable parameters and associated profiles.

Service Tool Features:

Using a PC connected to the controller and the Service Tool, the user can select between displaying system parameters, changing system parameters, setting the default values, loading new software, showing diagnostics and reporting on system parameters.

Standard default configurations are provided and can be used as a starting point for any custom configurations. New configuration settings can be saved as a parameter file with an .apf extension, for later use or to compile a different file for each machine using a quad controller. The service tool can access the .apf file(s) to write the settings to another quad controller.

The reporting feature can be used to extract controller parameter settings in a text format for any text editor program. The data-logging feature is used for listing diagnostic information in a text format for Excel. The user can then analyze and graph the information. This data-logging feature can be used for remote diagnosis by emailing the files to colleagues or Axiomatic.

1. Setting Up PC Communications to the Controller

- Connect a RS-232 cable to the mating plug for the black connector on the controller.
- If an Axiomatic wire harness is not used, then follow the pin out shown below for connection of the quad controller to a female DB-9.
 - Controller - Black Connector, Pin 7 -> TXD -> DB-9 Pin 2
 - Controller - Black Connector, Pin 8 -> RXD -> DB-9 Pin 3
 - Controller - Black Connector Pin 9 -> GND -> DB-9 Pin 5
- Connect the DB-9 end of the cable to a serial port on a PC.
- Use a stable power supply anywhere from +8V to +36V. **With the power supply OFF**, connect the controller Power- to the power supply Ground, and the Power+ to the power supply +.
- Load the Service Tool file using the Windows Run command. It may be necessary to use the Microsoft .NET framework to run the installation. It is supplied with the Service Tool.
- Once the Service Tool has been successfully opened, it is ready to use.
- Refer to the user manual for detailed instructions on using the Service Tool.

Note: CANopen® is a registered community trade mark of CAN in Automation e.V.

Specifications are subject to update without notice.
Form: TDAX020509-06/12/23