

## REMOTE MOUNT SOLENOID DRIVER

(0-5 VDC/0-20 mA/10K Potentiometer Input)

### Part No.:

PCB Board - RSD-PCB-5V-x

DIN Rail Mount – RSD-DR-5V-x

Metal Box Driver (board installed in metal box)

Available with no cable - RSD-SMB-5V-x-00

IP67 rated, with solid round cable - 5 ft. (1.5m) -

RSD-SMB-5V-x-IP7-yM

Clear cover, 1.5 m cable, 2A output –

AXRSDSMB5V2A1C

Where x = maximum current output

(2A, 1.2A, 800 MA, 600MA or 400MA)

y = 1.5 or custom lengths (meters)

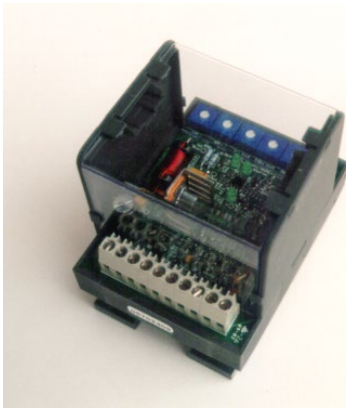
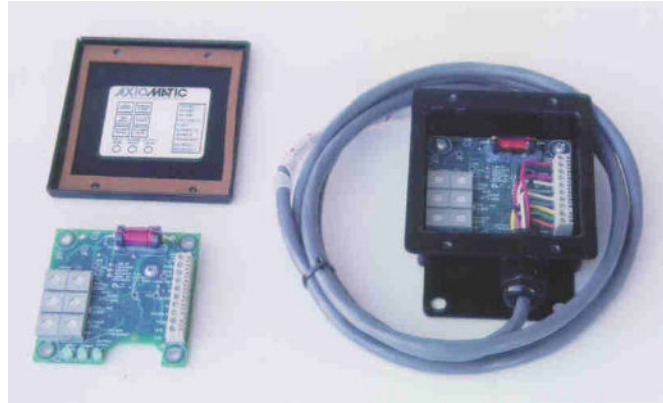

### Descript

ion: The

Remote Mount Solenoid Driver simplifies control of proportional solenoids by supplying a current proportional to an input control (0-5 VDC, 0-20 mA, potentiometer or pre-set level). It accepts power supply voltages from 9 to 28 VDC. This linear solenoid driver utilizes high frequency switching output (PWM) to provide a DC current output. A current sensing circuit maintains output current regardless of changes in input voltage and coil resistance. The options for maximum current output include 2 A, 1.2 A, 800 mA, 600 mA or 400 mA. The user can adjust maximum and minimum current. Ramp time, dither frequency and amplitude can also be adjusted to match the application. A system of LED's indicates output power level, input level and power on/off. The unit is available as a stand alone PCB Board, DIN rail mount version or as a Metal Box Driver enclosed in an IP65 or IP67 rated metal housing with cable or connectors provided. It is designed for remote mounting. Other versions are available including 4-20 mA signal input, 0-10 VDC signal input and DIN

43650 coil mount versions.

**Application:** Accurate control of hydraulic or pneumatic proportional solenoid valves in mobile equipment or industrial processes

### Features:

- Stand alone PCB Board, DIN rail mount version or enclosed in a metal housing with cable (3 connectors or no cable optional)
- Maximum current adjustment does not affect minimum current setting
- Current sensing circuit maintains output current regardless of changes in input voltage and coil resistance
- Broad range of supply voltages (9 to 28 VDC) with no degradation in performance
- Modern technology utilizing high frequency switching output (PWM)
- Energy efficient design (no heat sink is required)
- Accepts a 10K Potentiometer, 0-5 VDC or 0-20 mA inputs (0-10 V or 4-20 mA input versions available)
- Options for maximum current output include 2 A, 1.2 A, 800 mA, 600 mA or 400 mA
- LED indication of output power level, input level and power on/off
- Simple implementation of "soft shift" control with minimal external components
- Electronic limiting circuit means no internal fuses
- Short circuit proof (in case of solenoid failure or miswiring)
- CE certified for EMC
- UL and cUL versions available on request
- Metal box version carries IP67 rating
- Reverse polarity protected
- Filter eliminates electrical noise

# BLOCK DIAGRAM (0-5VDC Remote Mount Solenoid Driver)

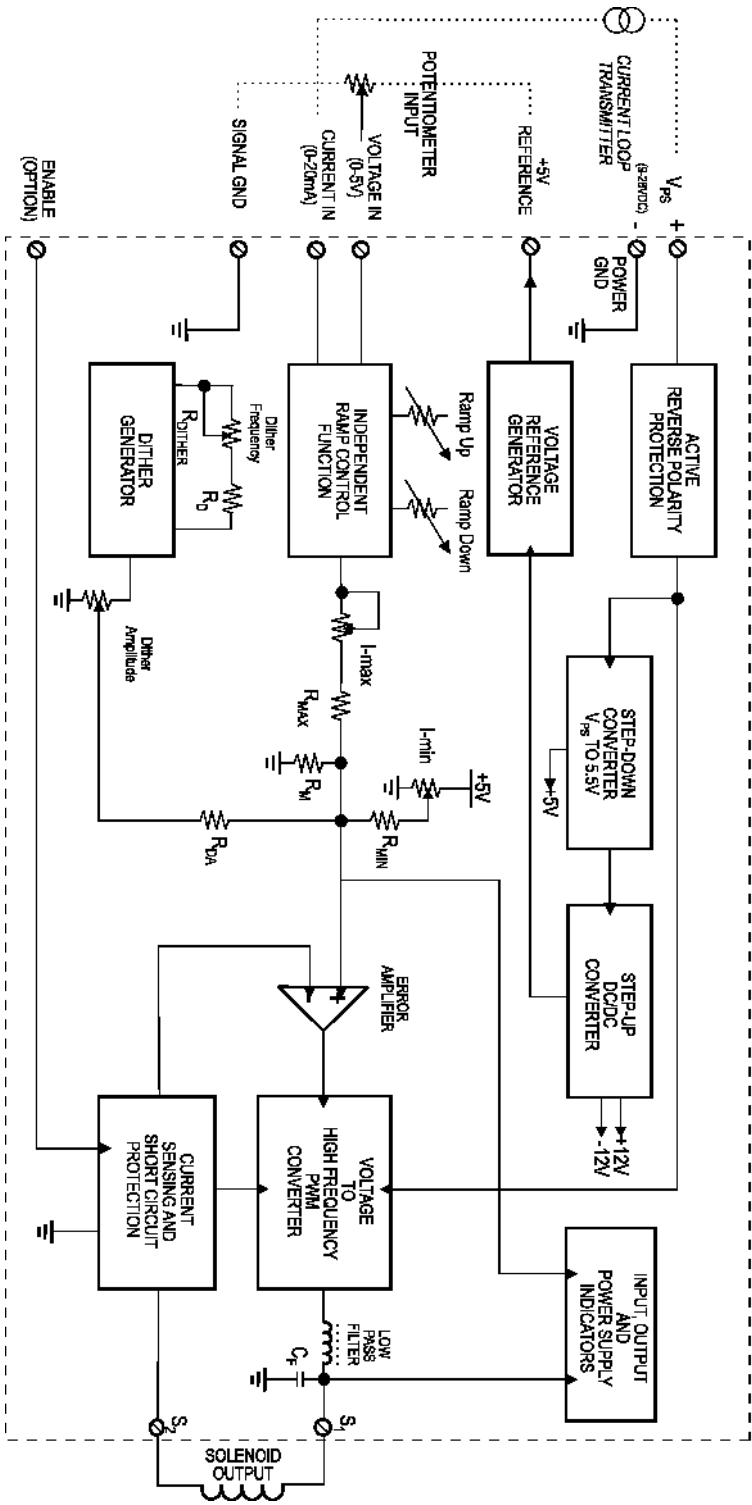

**Technical Specifications:** All specifications typical at nominal input voltage and 25°C unless otherwise specified.

*Specifications are indicative and subject to change. Actual performance will vary depending on the application and operating conditions. Users should satisfy themselves that the product is suitable for use in the intended application.*

*All our products carry a limited warranty against defects in material and workmanship. Please refer to our Warranty, Application Approvals/Limitations and Return Materials Process as described on <https://www.axiomatic.com/service/>.*

## General Specifications

Quiescent current	13.7 mA @ 12VDC 10 mA @ 24VDC
Operating conditions	-40 to +85 degrees C (-40 to 185°F) 0 to 85% relative humidity
Storage temperature	-50 to +125 degrees C (-58 to 257°F)
Electromagnetic compatibility (EMC)	Emission EN 50081-2; Immunity EN 50082-2
Approvals	CE (Metal Box Driver or DIN rail versions only) <i>The PCB Board and DIN rail mount versions are sold as components.</i>
Protection – Metal Box Driver	IP65 with nitrile lid gasket and cable installed IP67 with nitrile lid gasket and cable installed
Protection – DIN Rail Mount	IP00 Circuit board is conformally coated.
Electrical connection - PCB Board, DIN Rail Mount or Metal Box Driver (no cable, strain relief)	10 screw terminals accept 16-20 AWG wire for the power conductors and 18-24 AWG wire for the signal conductors
Electrical connection - Metal Box Driver with cable	Unterminated cable 5 ft. (1.5m) standard length <i>(A DIN 43650 coil mount version is also available.)</i>
Electrical connection - Metal Box Driver with connectors	<i>Solenoid</i> - Brad Harrison 45360-001 nano-change receptacle (3-pole male) <i>Signal Input</i> - Brad Harrison 45360-001 nano-change receptacle (3-pole male) <i>Power Input</i> – Brad Harrison 8R4E06A18A120 micro-change single keyway receptacle (4-pole male) <i>Mating plug with cable assemblies are available.</i> <i>Contact manufacturer.</i>
Cable clamp (grommet) size Max. cable diameter Wire size - cable in IP65 rated Metal Box Driver Wire size - cable in IP67 rated Metal Box Driver	PG9 screw type 5.00 to 7.92 mm (0.200 to 0.312 in.) 9 insulated wires AWG 20 plus drain wire 1 twisted quad AWG 18 (1.0 mm <sup>2</sup> ) and 5 insulated wires AWG 24 (0.25 mm <sup>2</sup> ) plus drain wire
Dimensions - PCB Board	63.5 x 20.3 x 63.5 mm (W x D x H) 2.5 x 0.8 x 2.5 inches
Dimensions – DIN Rail Mount	90.0 x 68.0 x 70.0 mm 3.54 x 2.67 x 2.75 inches (W x L x H excluding DIN rail foot)
Dimensions – Metal Box Driver with cable	114.3 x 27.9 x 79.4 mm 4.50 x 1.01 x 3.13 inches (W x D x H excluding grommet and cable)
Dimensions – Metal Box Driver with connectors	114.3 x 39.0 x 110.64 mm 4.50 x 1.53 x 4.35 inches (W x D x H including mounting plate and connectors)
Weight	PCB Board 0.10 lbs. (0.045 kg) DIN Rail Mount 0.30 lbs. (0.136 kg) Metal Box Driver with Cables (1.5m) 1.25 lbs. (0.567 kg) Metal Box Driver with Connectors 1.10 lbs. (0.499 kg)

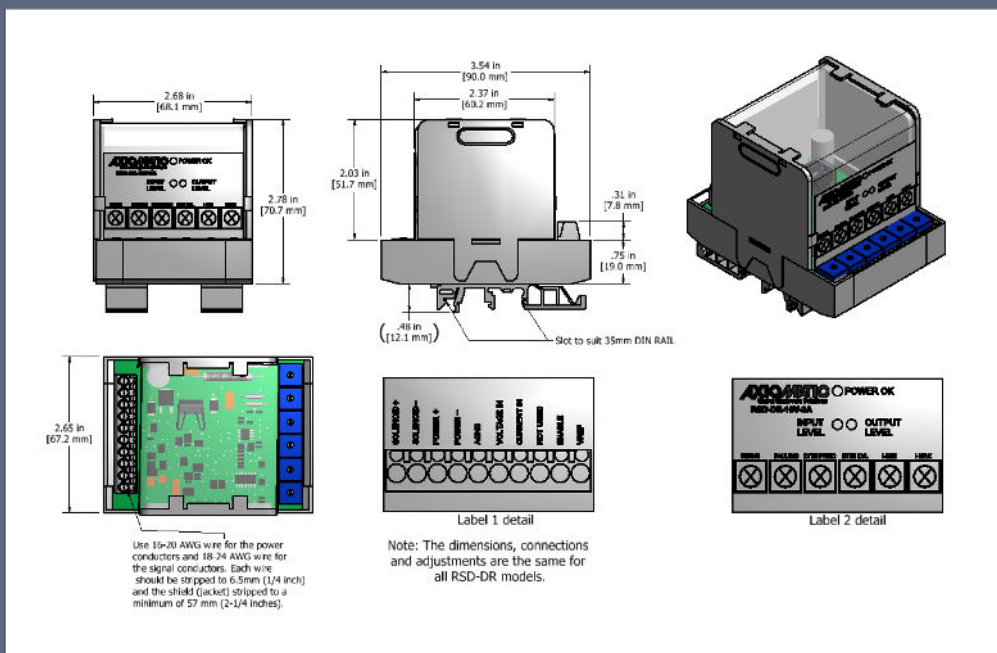
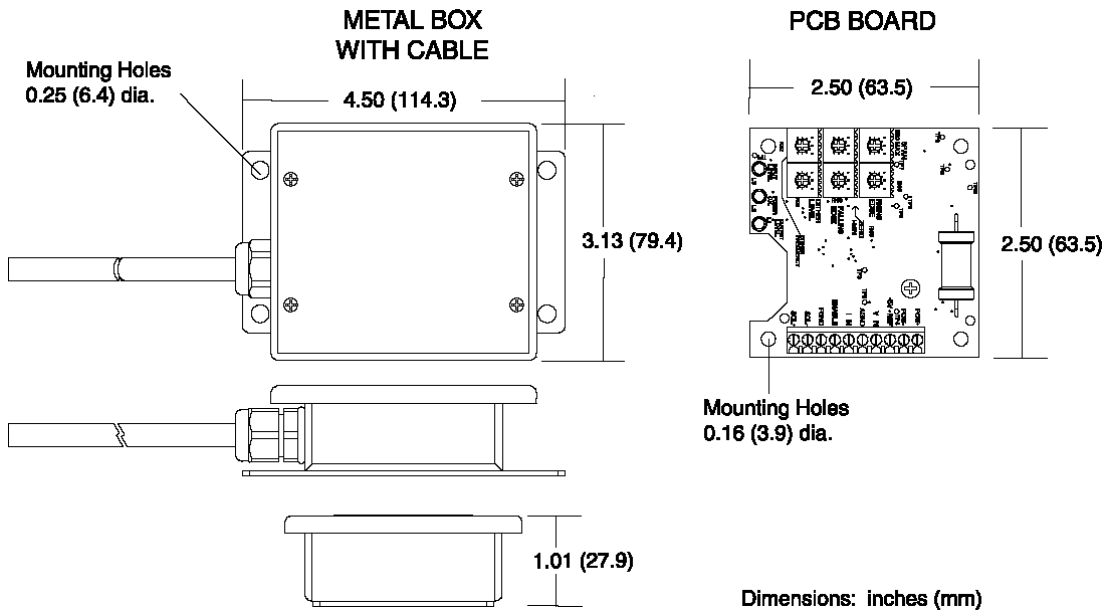

**DIN RAIL REMOTE MOUNT SOLENOID DRIVER**

## Electrical Specifications

Operating voltage (power supply requirement)	9 to 28 VDC power supply range
Control input signal options	0-5 VDC voltage signal or 0-20 mA current signal (max. 30 mA) or 10K Potentiometer (accepts 10K to 50K pots) or for soft shift control, pre-set the solenoid driver by connecting +5VDC to input and use the I-max. adjustment (0-10 VDC and 4-20 mA input versions available) Refer to Notes below for proper installation.
Input resistance	Voltage mode: 250K Ohms Current mode: 33 Ohms
Range of maximum output current	2 A (1.2 A, 800 mA, 600 mA and 400 mA versions) <i>Refer to ordering codes for available models.</i>
Solenoid resistance selection (nominal)	Nominal resistance of solenoid coil should comply with: $R_{coil} \leq (V_{powersupply} - 1.5 V) / I_{max}$
Internal supply for setpoint potentiometer	+5 VDC (See Note 4.)

Note 1: For proper operation, match the power supply voltage with rating of solenoid coil. Operating the driver with a supply voltage lower than the solenoid rated voltage may result in reduced maximum current output.

Note 2: Since the output is filtered (not switched), no external protection diodes are necessary.

Note 3: The maximum current output of the driver should not exceed the current rating of the solenoid coil.

Note 4: WARNING: The control input and the +5V reference lines should never be connected to the power supply input line. This will damage the controller.

## Adjustments

Minimum current setting	0 to 500 mA (for 2 A output model) 0 to 300 mA (for 1.2 A output model) 0 to 150 mA (for 800 mA output model) 0 to 150 mA (for 600 mA output model) 0 to 100 mA (for 400 mA output model)
Maximum current setting	0.6 to 2.0 A (for 2 A output model) 0.36 to 1.2 A (for 1.2 A output model) 300 to 800 mA (for 800 mA output model) 180 to 600 mA (for 600 mA output model) 120 to 400 mA (for 400 mA output model)
Current ramp time	0.01 - 5 sec. independent
Dither amplitude Dither waveform Current dither frequency	0 to 10% of rated maximum current Triangular 70 to 350 Hz ( $\pm 10\%$ of full scale)

## Mounting Instructions and Wiring Connections: For stand alone PCB Boards:

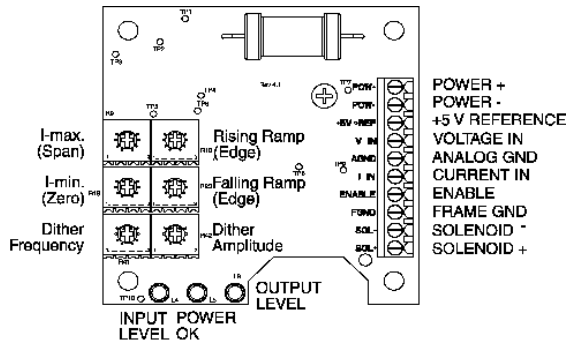

### Mounting the PCB board

- The board will accommodate #6 size mounting screws (not supplied).

### Connecting to the screw terminals on the board

- Use a cable to connect to the PCB board with each wire stripped to 6.5 mm (1/4 inch) and the shield (jacket) stripped to permit splaying of the wires in the screw terminals without tension. The exposed ground shield wire should have a heat shrink placed around the wire as a precautionary measure.
- Reference the label (included with the board) for the pin out connections of the screw terminals.
- To connect the cable to the board, loosen each screw terminal, insert the pre-tinned wire and tighten with a jeweller's sized screwdriver. **Take care to position the ground shield wire away from the PCB Board.**

## For Metal Box Drivers with/without cable (Metal Box):

### Mounting the housing

Mount the housing using four #10-32 bolts or screws.

### Connecting to the screw terminals on the board

For models where no cable is provided connect a cable as follows. For a cable specification, refer to the technical specification section.

- To access the screw terminals, loosen the four screws on the lid using a Phillips #1 screwdriver. Remove the lid.
- Use a 0.200 to 0.312 inch diameter solid round shielded cable to connect to the remote mount solenoid driver. Each wire should be stripped to 6.5 mm (1/4 inch) and the shield (jacket) stripped to a minimum of 57 mm (2-1/4 inches). Exposed ground shield wire should have a heat shrink placed around the wire as a precautionary measure.
- Remove the clamp nut on the Heyco PG9 grommet using an adjustable wrench.
- Slide the clamp nut over the cable. Insert the cable into the grommet, allowing for the stripped minimum of 2 1/4 inches to be available inside the housing. Tighten the clamp nut securely attaching the cable to the housing assembly.
- Reference the label (found on the inside of the lid) for the pin out connections of the screw terminals.
- To connect the cable to the board, loosen each screw terminal, insert the pre-tinned wire and tighten with a jeweller's sized screwdriver. **Take care to position the ground shield wire away from the PCB Board.**
- Replace the lid and gasket. Replace and tighten the four 4-40 Phillips flat head screws.

**Connecting the cable**

For models where the cable is supplied, connect the cable to the load, power supply and input signal or potentiometer, as follows.

For Potentiometer, 0-20 mA or 0-5 VDC Control:

Turn ramp screws fully counterclockwise to eliminate ramping.  
 Use I-Min. screw to set up minimum speed with minimum control input.  
 Use I-Max. screw to set maximum speed with 100% of control input.  
**WARNING:** The control input and the +5V reference lines should never be connected to the power supply input line. This will damage the controller.

**Enable:**

When Enable is connected to the -ve power supply, the unit will be disabled. When Enable is left open or connected to the +ve power supply, the unit is enabled.

**IP67 Rated Driver with Cable – Wiring Diagram**

**WARNING:** The control input and the +5V reference lines should never be connected to the power supply input line. This will damage the controller.

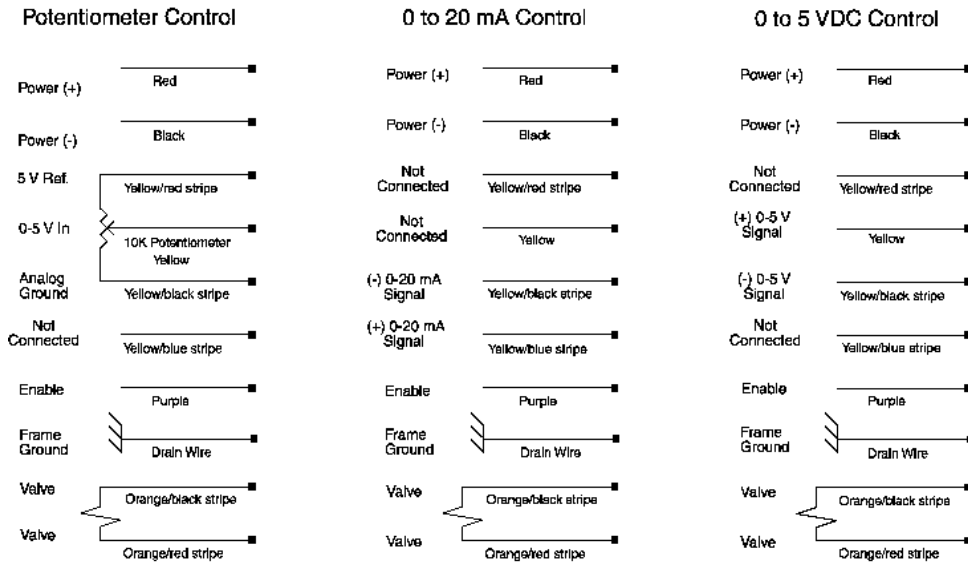

Refer to page 2 (block diagram) for an alternative method of connecting a current loop transmitter to provide a current control signal input. In this method, the current loop transmitter receives power from the power supply powering the amplifier. The transmitter is connected to the driver's +power supply input wire and the +0 to 20 mA input wire. This method does not use the -0 to 20 mA signal wire connection.

## For Metal Box Drivers with three connectors (Metal Box):

### Mounting the housing

Mount the housing using four #10-32 bolts or screws.

### Connector Pin Out:

For Either Potentiometer, 0-5 VDC or 0-20 mA Control:

Turn ramp trim pot fully counterclockwise to eliminate ramping.

Use I-Min. trim pot to set minimum speed with minimum control input.

Use I-Max. trim pot to set maximum speed with 100% of control input.

Enable:

When Enable is connected to the -ve power supply or Analog GND screw terminal, the unit will be disabled.

When Enable is left open or connected to the +ve power supply, the unit is enabled.

Mating plug and cable assemblies are available. Contact the manufacturer. The pin out shown below is for the three male connectors mounted in the metal box.

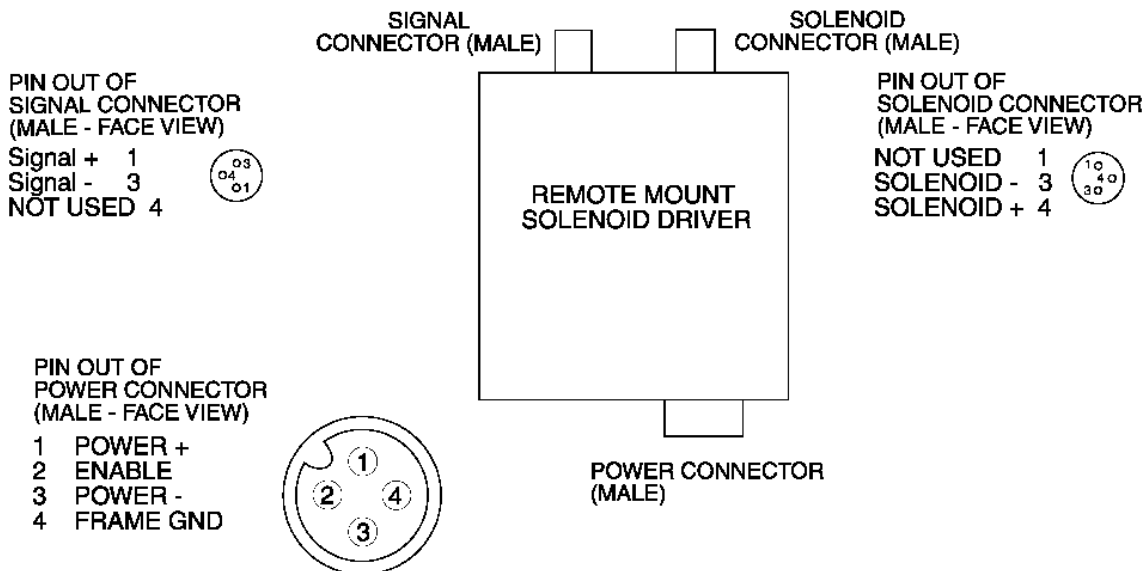

## For DIN Rail Mount Drivers:

### Mounting the housing

The DIN Rail Mount Driver has a universal foot for mounting on the DIN rail.

### Connecting to the screw terminals on the board

- Use 16-20 AWG wire for the power conductors and 18-24 AWG wire for the signal conductors in a solid round shielded cable to connect to the remote mount solenoid driver. Each wire should be stripped to 6.5 mm (1/4 inch) and the shield (jacket) stripped to a minimum of 57 mm (2-1/4 inches). Exposed ground shield wire should have a heat shrink placed around the wire as a precautionary measure.
- Reference the label for the pin out connections of the screw terminals.
- To connect the cable, loosen each screw terminal, insert the pre-tinned wire and tighten with a jeweller's sized screwdriver. **Take care to position the ground shield wire away from the PCB Board.**

Enable: When Enable is connected to the -ve power supply, the unit will be disabled. When Enable is left open or connected to the +ve power supply, the unit is enabled.



## Adjustment Details:

Ensure that the unit is connected to an operating proportional valve. Use a Phillips #1 screwdriver to make adjustments to the trim pots. The torque rating for the trim pots is 5.0 oz-in. max.

The following settings represent a typical set up for a voltage or current signal input. Conditions will vary for other set up scenarios. Trim pots are single turn. Use a Phillips #1 screwdriver to adjust the single turn trim pots.

### PCB Board and Metal Box Driver versions

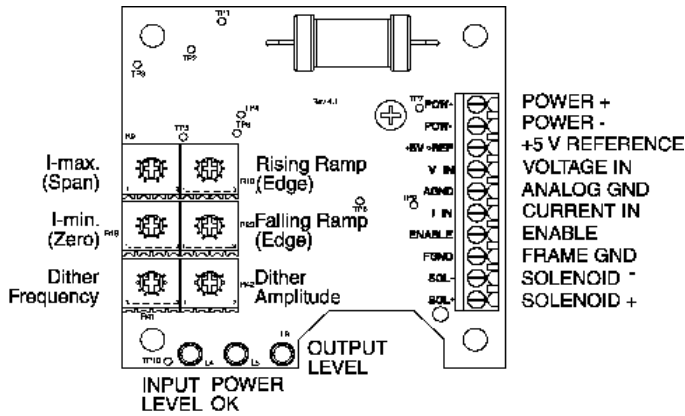

### DIN Rail Mount version

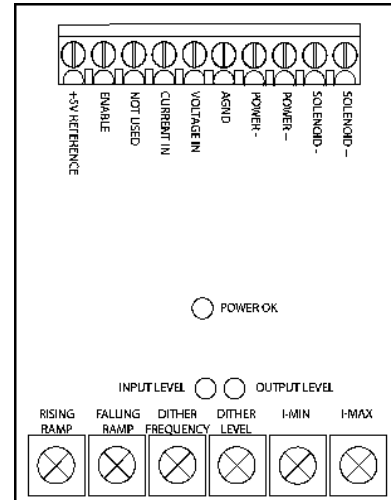

In the Metal Box Driver, adjustments are accessible by loosening the four screws on the lid of the housing and removing the lid.

Trim Pot Adjustments	Range of Adjustment	Factory Setting
Zero - Minimum Current Setting (I-min.)	0 to 0.5 A (for 2 A output model) 0 to 0.3 A (for 1.2 A output model) 0 to 150 mA (for 800 mA output model) 0 to 150 mA (for 600 mA output model) 0 to 100 mA (for 400 mA output model)	0% (CCW)
Span - Maximum Current Setting (I-max.)	0.6 to 2.0 A* (for 2 A output model) 0.36 to 1.2 A (for 1.2 A output model) 300 to 800 mA (for 800 mA output model) 180 to 600 mA (for 600 mA output model) 120 to 400 mA (for 400 mA output model)	100% (CW)
Ramp Time (Rising and Falling Edge)	0.01 to 5 seconds independent	minimum (0.01 sec.) (CCW)**
Dither Level (Amplitude)	0 to 10% of rated maximum current	0% (CCW)
Dither Frequency	70 to 350 Hz ( $\pm 10\%$ )	minimum (CCW)

CW = clockwise, CCW = counterclockwise

\*NOTE 1: Range of maximum output current is 2A (maximum output current = minimum current setting + maximum current setting).

\*\*NOTE 2: To eliminate ramping, turn the trim pots fully counterclockwise.

Adjusting the minimum current will shift the maximum current setting, as shown.

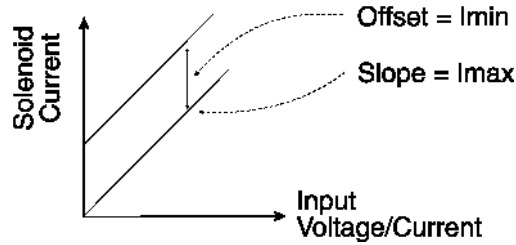

Adjusting the maximum current ( $I_{max}$ ) does not affect the minimum current ( $I_{min}$ ) setting.

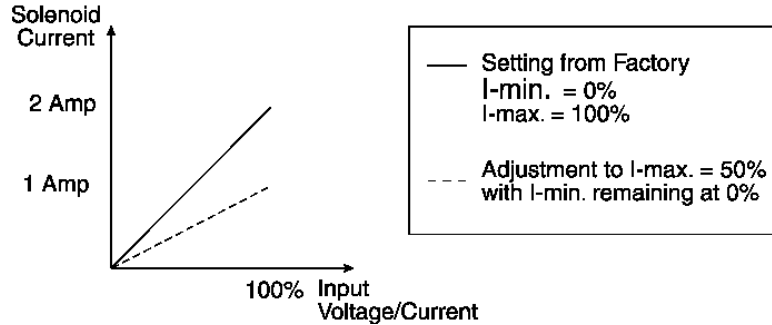

### Setting the Minimum Current ( $I_{min}$ .)

The minimum current setting can be used to take into account the mechanical valve deadband and provide desired offsets from zero to allow full control within the functional range of the specific valve.

- **Set the minimum current before setting the maximum current.**
- Apply minimum input (control potentiometer at minimum or 0 V or 0 mA).
- The factory setting for the  $I_{min}$  trim pot is set at 0 or fully counterclockwise (CCW).
- If the desired minimum current is greater than 0, adjust the trim pot clockwise (CW) until the desired current is achieved.

### Setting the Maximum Current ( $I_{max}$ .)

- Apply maximum control (control pot at maximum or 5 V or 20 mA).
- The factory setting for the  $I_{max}$  trim pot is 100% or fully CW.
- Turn the trim pot CCW to adjust the current setting downwards to the desired maximum.

The maximum current setting is adjusted to meet the customer's working pressure or flow range to the full scale signal input range. This provides maximum control for a specific application. *For example, a 5 VDC input can represent a 500 mA output (versus a 2 A output) if the valve requires this maximum current for its control function application.*

Current output should be measured by an ammeter set up in series with the driver and the load. Connect the Solenoid + output to the + terminal on the Ammeter and the Ammeter to the Solenoid. Connect the Solenoid - output to the Solenoid.

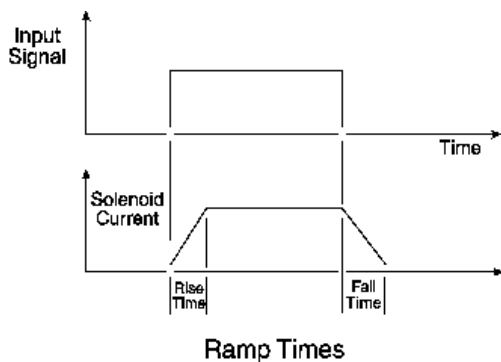
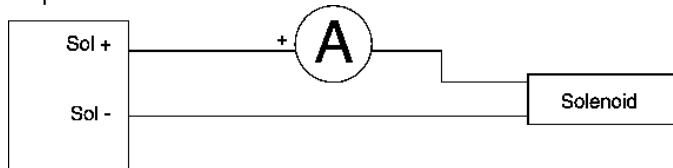

### Setting the Ramp Times

- The factory setting for ramp times is the minimum (0.01 seconds) or fully CCW.
  - **If the ramp time settings are not needed, leave the setting at the minimum value.**
  - To change the ramp times, adjust the trim pot CW to increase the time.
  - Note that rising and falling ramp times are independent.
- Ramp times are application dependent. They limit the rate of change or how fast the operation happens. Note that if the input signal is not applied long enough for the ramp time set, the desired solenoid current will not be reached.

## Setting the Dither Amplitude

- The factory setting for dither amplitude is 0% (CCW).
- To adjust dither amplitude, turn the trim pot CW until small changes in the input signal register similar changes in current output.
- Choose the smallest effective dither amplitude.

Dither amplitude is adjustable from 0 to 10% of the rated maximum current. Dither amplitude and frequency are dependent on the specific valve. The effects of static friction on the operation of the solenoid are reduced by the application of a small AC current. The hysteresis and repeatability of the valve are improved by this practice. The optimum dither amplitude is attained when small input signal changes register similar changes in current output (pressure or flow through the valve).

## Setting the Dither Frequency

- The factory setting for dither frequency is the minimum or 0% (CCW).
- To adjust dither frequency, turn the trim pot CW until the desired frequency is set.
- The valve manufacturer will provide the desired dither frequency rating for their product.

Measure the superimposed dither by attaching a digital multimeter (with a frequency setting) to the Test Point located next to the INPUT LEVEL LED and to the Analog GND screw terminal (for PCB and Metal Box Driver versions).

## Ordering Part Number:

**PCB Board** - RSD-PCB-5V-x

**Where x** = maximum current output (2A, 1.2A, 600MA or 400MA)

**DIN Rail Mount** - RSD-DR-5V-x

**Where x** = maximum current output (2A, 1.2A or 800MA)

**Metal Box Driver (board installed in housing assembly)**

**Available with no cable** - RSD-SMB-5V-x-00

**Where x** = maximum current output (2A, 1.2A, 600MA or 400MA)

**Available with 3 connectors** – RSD-SMB-5V-x-01 - NO LONGER AVAILABLE

Contact the manufacturer for mating plug and cable assemblies.

**IP67 rated and available with solid round cable - 5 ft. (1.5m)** - RSD-SMB-5V-x-IP7-1.5M

**Where x** = maximum current output (2A, 1.2A, 600MA or 400MA)

**Clear cover, 1.5 m cable, 2A output** – AXRSDSMB5V2A1C

Form: TD1500AX-06/15/23